

 **bitherm**



Intelligent steam traps and valves

DESCRIPTION AND OPERATION

Wireless SmartWatchWeb™ (SWW) is a monitoring system based on microprocessor whose management is performed remotely via Web platform LAMP (Linux, Apache, MySQL, PHP).

Each field unit SWW-10 has 4 input channels designed for different types of signals: ultrasound, temperature, pressure and gas detection. The signals from the sensors are processed by the field units SWW-10 and sent to the remote management system through either control units WCU-10 (wired) or End Devices & Routers (wireless) or combination of both physical media.

Each WCU-10 on End device ED-10 is connected to field units SWW-10 with a 4-wire cable (2 wires for power and 2 wires for data) in a RS-485 bus up to 1200 m in length, which can contain up to 125 field units SWW-10.

The system can handle up to 65,536 steam traps in a Single Control Center (SCC). However the Remote SWW Control Center (RCC) can be configured in cluster to handle a number of SCC. That way the SWW monitoring system has a huge scalability and availability.

The very efficient SWW hybrid wireless topology allows extending its range of coverage up to 15 Km away making it possible to monitor steam traps and valves anywhere in a large petrochemical complex.

One of the fundamental advantages of the network wireless SWW versus other wireless networks is the huge reduction of RF devices. Indeed, SWW uses one number of wireless devices 50 times less than other wireless networks (average). It means 50 times less batteries, too. In short, SWW reduces 50 times on average the cost of installation and maintenance of the system, and optimizes the efficiency of RF transmission to concentrate data packets from multiple elements (rather than transmit data of each element individually).

The use of rechargeable batteries with solar panels increases the useful life of batteries up to 15 years and supplies enough energy to convert SWW on a true monitoring system (measures and alarms) compared to other systems that only indicate alarms. In this way, SWW can perform measurements of various parameters and transmit them with the required frequency, without affecting the service life of batteries; eliminating one of the main problems of wireless systems.

TECHNICAL SPECIFICATIONS

WIRELESS ARCHITECTURE:

- Communications: Bidirectional
- Data transmission: Half Duplex
- Standard IEEE 802.15.4 wireless protocol
- RF Frequency: 2,4 GHz
- RF band: ISM (free band)
- Self-organizing, adaptive Mesh routing
- Very high efficiency of data transmission
 - a) High packaging of data (up to 125 computers per device).
 - b) Simplification of routing.
 - c) Elimination of collisions
- Transmit rate: User selectable 1 s to 60 min.
- RF power output from antenna: 20 dBm.
- RF range for router: 1,000 mt
- Maximum RF coverage: up to 15 Km
- Options of power supply:
 - a) 125/250 VAC, 7.5 VCC
 - b) Lithium battery with rechargeable battery with solar panels (15 years life)

MONITOR:

- Ultrasound Sensor: Piezoelectric 40KHz
- Temperature sensor: NTC (-20 / + 170 °C)
- Pressure sensor: 0-25 bar
- Gas detection: pellistor or infrared types
- Output resolution: 10 bits (0-1023 counts)
- Cable: 2x1.5 + 2x0.5, SAC HG 1.5 BC FLEX, armoured type, external diameter 18,5 mm, covered by PCV, fireproof.
- Body and cover: Aluminium.
- Protection: IP65, NEMA 4X weather-proof housing
- Maximum wire length: 1200 mt. (wire length longer than 1200 mt is available using RS-485 repeaters).

MOUNTING:

- No mounting hardware.
- Noninvasive installation even pressure sensors.
- External antenna 6/9 dBm for maximum range

OPERATING RANGE

- Pressure: 0 - 25 bar
- Process Temperature: -40 °C a 320 °C
- Ambient Temperature: -40 °C to 80 °C
- Gas detection: ppm (depending of gas type)

CERTIFICATIONS

Intrinsic safety: ATEX II1G. Ex ia IIC T4 Ga
Intrinsically Safe Zone 0, Division 1.

DIMENSIONS AND WEIGHT

- SWW-10 body: 90x90x80 mm (3.54x3.54x3.15 in)
- SWW-10 body and connections: 90x115x110 mm (3.54x4.52x4.33 in)
- Weight SWW-10: 0,7 Kg (1,55 lbs).

TYPICAL APPLICATIONS:

SmartWatchWeb system can be used for detecting and monitoring leaks of gases, steam and presence of dangerous gases on atmosphere on lots of applications:

- Improving energy efficiency
- Reducing leaks of process gas
- Reducing steam leaks
- Reducing CO2 emissions
- Prevention of risky situations.
- Improving safety conditions
- Monitoring steam traps and safety valves
- Reducing inspection costs
- Reducing maintenance costs

INSTALLATION

Easy to install. Non-invasive system, no penetration required (except pressure sensor applications).

Field units can be installed on any kind of steam trap, safety valve or on-off valve. Installation of field units on steam traps, safety valves, on-off valves is made by clamps or brackets. BiTherm steam traps do not require brackets, the sensor is mounted directly on the available connector on the top of the trap.



ARCHITECTURE

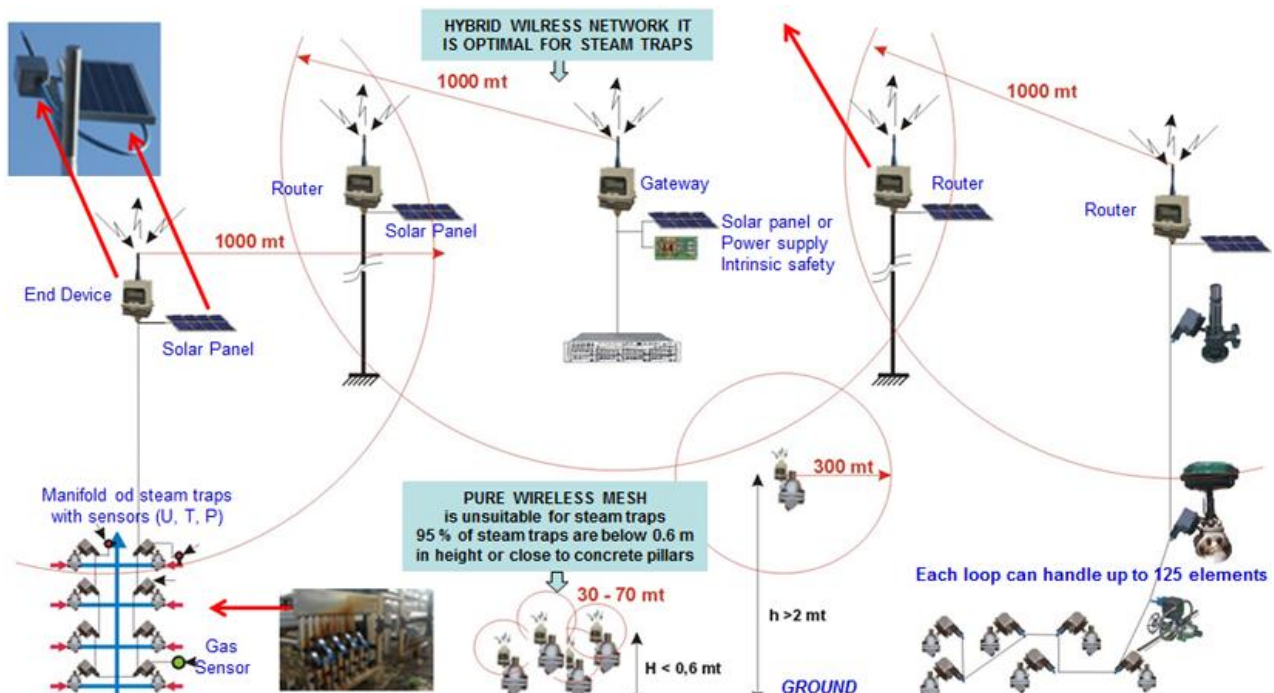

Technical modifications reserved

Internacional patents: US 6.338.283, ES 2133240, PCT/ES97/0181, EU 97931823.5

Copyright BiTherm 2011

PURGADORES DE CONDENSADO S.L.

Condesa de Venadito, 16, 11° C. 28027-MADRID (Spain)

<http://www.smartwatchweb.com>

DESCRIPTION AND OPERATION

SmartWatch™ is a monitoring system based on microprocessor whose management is performed remotely via Web platform LAMP (Linux, Apache, MySQL, PHP).

Each field unit SWW-10 has four input channels designed for different types of signals: ultrasound, temperature, pressure and gas detection. The signals from the sensors are processed by the field units SWW-10 and sent to the remote management system through control units WCU-10.

Each WCU-10 is connected to field units SWW-10 with a 4-wire cable (2 wires for power and 2 wires for data) in a line up to 1200 m in length, which can contain up to 125 field units SWW-10.

The system can handle up to 250 Control Units WCU-10, each of which can control up to 125 field units SWW-10 through an RS-485 bus. Thus, the system can handle up to 31.250 field units SWW10.

Alternatively, communications can be wireless RF.

TECHNICAL SPECIFICATIONS

- Communication: Bidirectional
- Data transmission: Half Duplex
- Ultrasound Sensor: Piezoelectric 40KHz
- Temperature sensor: NTC (-20 / + 170 °C)
- Pressure sensor: 0-25 bar
- Gas detection: pellistor or infrared types
- A/D converter: 10 channels, 10 bits
- Cable: 2x1.5 + 2x0.5, SAC HG 1.5 BC FLEX, armoured type, external diameter 18,5 mm, covered by PCV, fireproof.
- Power:
 - Wired: 125/250 VAC, 7.5 VCC
 - Wireless SWW: Lithium battery 7.2 VDC
 - Wireless WCU: Rechargeable battery Li-ion 3,75 VDC and solar panel.
- Protection: IP65, NEMA 4X weather-proof housing
- Certification: ATEX II 1G (EEx ia IIC T4). Intrinsically Safe Zone 0, Division 1.
- Maximum wire length: 1200 mt. (wire length longer than 1200 mt is available using RS-485 repeaters).
- Maximum range RF system: Several Km (depending on environment conditions and number of repeaters)
- RF Frequency: 2,4 GHz

OPERATING RANGE

- Pressure: 0 - 25 bar
- Process Temperature: -30 °C a 220 °C
- Ambient Temperature: -40 °C to 80 °C
- Gas detection: ppm (depending of gas type)



MATERIALS

- Brass/Cast aluminum base.
- Cast aluminum cover.
- Cover bolts: stainless steel.
- Optional stainless steel hardware.

DIMENSIONS AND WEIGHT

- SWW-10 body: 90x90x80 mm (3.54x3.54x3.15 in)
- SWW-10 body and connections: 90x115x110 mm (3.54x4.52x4.33 in)
- Weight SWW-10: 0,7 Kg (1,55 lbs).

TYPICAL APPLICATIONS:

SmartWatchWeb system can be used for detecting and monitoring leaks of gases, steam and presence of dangerous gases on atmosphere on lots of applications:

- Improving energy efficiency
- Reducing leaks of process gas
- Reducing steam leaks
- Reducing CO2 emissions
- Prevention of risky situations.
- Improving safety conditions
- Monitoring steam traps and safety valves
- Reducing inspection costs
- Reducing maintenance costs

INSTALLATION

Easy to install. Non-invasive system, no penetration required (except pressure sensor applications). Field units can be installed on any kind of steam trap, safety valve or on-off valve.

Installation of field units on steam traps, safety valves, on-off valves is made by clamps or brackets. BiTherm steam traps do not require brackets, the sensor is mounted directly on the available connector on the top of the trap.



ARCHITECTURE AND USER INTERFACE

The system is remotely handled by a friendly graphic interface shown below:

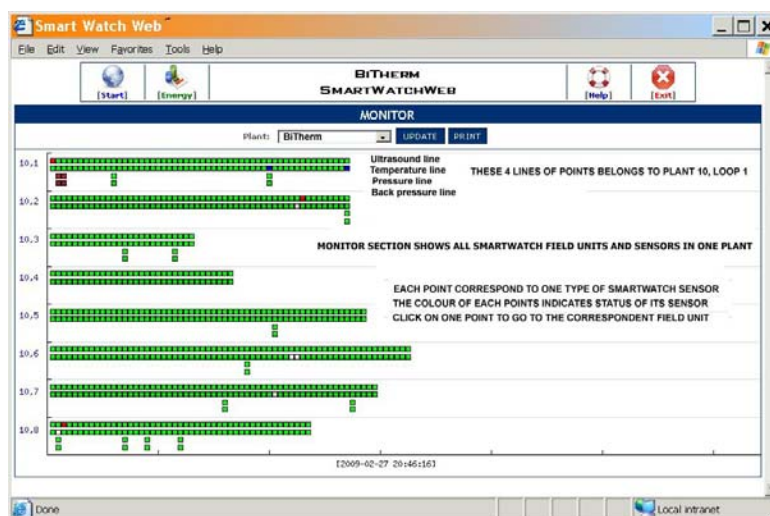
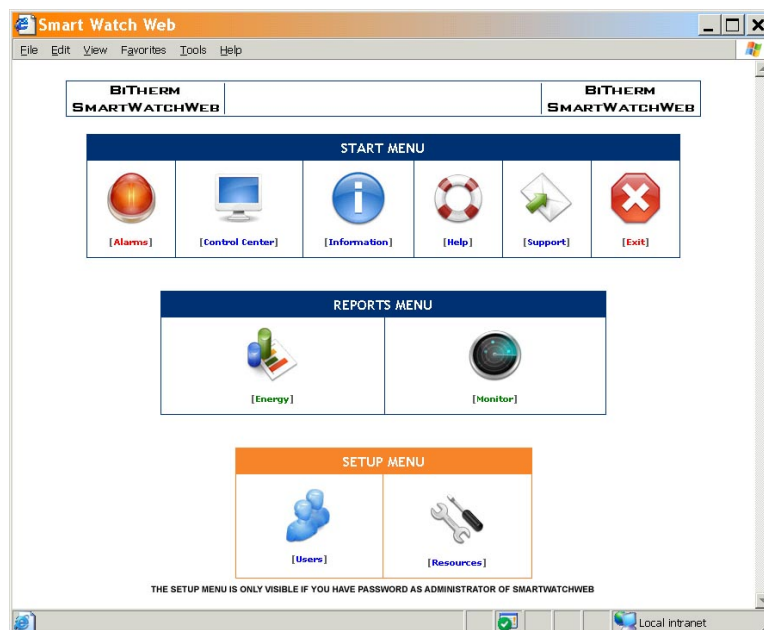

Technical modifications reserved

Copyright BiTherm 2011

PURGADORES DE CONDENSADO S.L.
Condesa de Venadito, 16, 11° C. 28027-MADRID (Spain)
<http://www.smartwatchweb.com>

DESCRIPTION

LeakTector is a portable gas or steam leak detector, designed for periodical survey of steam traps and valves. It detects abnormal vibrations on rotary machines, as well.

When a gas or steam leak is produced through an orifice, or through a valve, the high speed of the gas or steam generates a sound of high frequency (ultrasound), which is not audible by the human ear. This ultrasound is captured and analyzed by the Leaktector microprocessor and finally shown its result on the LCD display.

The system is integrated by two components: probe and analyzer.

A novelty of LeakTector is its special verification function of thermodynamic steam traps, allowing the evaluation of the low energetic efficiency states (cycle too short) of this type of steam traps.

OPERATION

The device operation is extremely easy. It includes only one multifunction button and a turn of/off switch. The multifunction button allows selecting the sensitivity of the analyzer, which can be selected among six different ranges:

1. LP: (High sensitivity, for low pressure >15 psig and < 50 psig).
2. MP: (Medium sensitivity, for median pressure >50 psig and < 250 psig).
3. HP: (Low sensitivity, for high pressure > 250 psig).
4. TD Specific function for Thermodynamic steam traps.

INCLUDED ACCESSORIES

- Transport pocket.
- TrapHelp (steam trap survey software (limited to 500 records).

APPLICATIONS

- Steam trap survey.
- Gas and steam leaks detection.
- Vibration detection in rotary machines.

Copyright BiTherm 2009
Technical modifications can be introduced without any advise.

**TECHNICAL CHARACTERISTICS**

Body: High impact polystyrene. Black color.
Frequency: 40 KHz +/- 1 KHz
Bandwidth (-6dB): 2 KHz
Sensitivity: -80dB/V/μbar
Protection: IP54.
Max. Temperature: -30°C + 80 °C.
Display: Backlight LCD 12 x 2 lines.
Dimensions: 3.5 x 3 x 1.5 inches.
Weight: 0.6 lbs.

OPTIONAL ACCESORIES

1. Battery charger (only when LT3 is supplied with rechargeable battery)
2. Interchangeable directional probe.
Directional probe is used for gas leak detection at distance of 5 to 10 mt. without touching the source of leakage. Unaccessible gas leak is detected by pointing the directional probe to the leakage source. Size of directional probe is similar to size of the contact probe.

BATTERIES

The LT-3 can be delivered with two diferent types of batteries:

1. Rechargeable Li-HM battery:
1 x 9 VCC (PP3/6LF22, 9V/260 mAh).
Continuous live: 87 hours (backlight off).
2. Non rechargeable Alkaline battery:
1 x 9 VCC (PP3/6F22, 9V, 550mAh)
Continuous live: 183 hours (backlight off).

It is strongly suggested using rechargeable batery plus charger to avoid remove cover of LT3.

PURGADORES DE CONDENSADO, S.L.

Condesa de Venadito, 16, 11° 28027 - MADRID

Phone: + 34 91 404 8087 www.smartwatchweb.com email: purgasa@bitherm.com

DESCRIPTION

LeakTector is a portable gas or steam leak detector, designed for periodical survey of steam traps and valves. It detects abnormal vibrations on rotary machines, as well. It has intrinsic safety certification, ATEX II 1G, grade Ex ia IIC T4.

When a gas or steam leak is produced through an orifice, or through a valve, the high speed of the gas or steam generates a sound of high frequency (ultrasound), which is not audible by the human ear. This ultrasound is captured and analyzed by the LeakTector microprocessor and finally shown its result on the LCD display.

The system is integrated by two components: probe and analyzer.

A novelty of LeakTector is its special verification function of thermodynamic steam traps, allowing the evaluation of the low energetic efficiency states (cycle too short) of this type of steam traps.

OPERATION

The device operation is extremely easy. It includes only one multifunction button and a turn of/off switch. The multifunction button allows selecting the sensitivity of the analyzer, which can be selected among six different ranges:

1. LP: (High sensitivity, for low pressure >15 psig and < 50 psig).
2. MP: (Medium sensitivity, for median pressure >50 psig and < 250 psig).
3. HP: (Low sensitivity, for high pressure > 250 psig).
4. TD Specific function for Thermodynamic steam traps.

INCLUDED ACCESSORIES

- Transport pocket.
- TrapHelp (steam trap survey software (limited to 500 records).

APPLICATIONS

- Steam trap survey.
- Gas and steam leaks detection.
- Vibration detection in rotary machines.

Copyright BiTherm 2011

Technical modifications can be introduced without any advise.

**TECHNICAL CHARACTERISTICS**

Body: High impact polystyrene. Black color.
 Frequency: 40 KHz +/- 1 KHz
 Bandwidth (-6dB): 2 KHz
 Sensitivity: -80dB/V/μbar
 Protection: IP54.
 Max. Temperature: -30°C + 80 °C.
 Display: Backlight LCD 12 x 2 lines.
 Dimensions: 3.5 x 3 x 1.5 inches.
 Weight: 0.6 lbs.

OPTIONAL ACCESORIES

1. Battery charger (only when LT3-EX is supplied with rechargeable battery)
2. Interchangeable directional probe.
 Directional probe is used for gas leak detection at distance of 5 to 10 mt. without touching the source of leakage. Unaccessible gas leak is detected by pointing the directional probe to the leakage source. Size of directional probe is similar to size of the contact probe.

BATTERIES

The LT-3 can be delivered with two diferent types of batteries:

1. Rechargeable Li-HM battery:
 1 x 9 VCC (PP3/6LF22, 9V/260 mAh).
 Continuous live: 87 hours (backlight off).
2. Non rechargeable Alkaline battery:
 1 x 9 VCC (PP3/6F22, 9V, 550mAh)
 Continuous live: 183 hours (backlight off).

It is strongly suggested using rechargeable batery plus charger to avoid remove cover of LT3-EX.

PURGADORES DE CONDENSADO, S.L.

Condesa de Venadito, 16, 11° 28027 - MADRID

Phone: + 34 91 404 8087 www.smartwatchweb.com email: purgasa@bitherm.com

Presentation:

TrapHelp™ is a software specially designed to provide complete information about all the elements that constitute the trap valve stations in large facilities.

In its design, it has been paid particular attention to ease of use without losing of performance. Indeed, the initial screen contains not only all the information for each trap valve station but its inspection historic, repair historic, estimation of energy losses, estimation of repair costs, calculation of payback period (ROI), as well as all the commands that allow users to add, modify, insert or delete any partial or complete information regarding to any trap valve station.

Features:

TrapHelp™ is not a simple generic data base suitable for a particular application but a software specifically designed for inspection, repair and maintenance of trap valve stations, which incorporates the most advanced features, such us:

- Supports Windows 9x/NT/XP,
- Unlimited number of trap valve stations,
- Allows to include in the data base all elements that constitute the trap valve station,
- Fast data entry by keyboard or mouse,
- Help displayed on the screen through dropdown lists in all data fields,
- Predefined reports and graphs, such as:
 - Inspection and general status,
 - Pending repairs,
 - Inspection historic.
- Estimation of energy losses,
- Customizable reports by the user through different and multiple criteria or parameters, such as:
 - Brand and model,
 - Application,
 - Status,
 - Repairs made, etc.
- Free definition of brands, models and features of steam traps,
- Free application definition,
- Free definition of services,
- Free definition of concepts and repair costs.

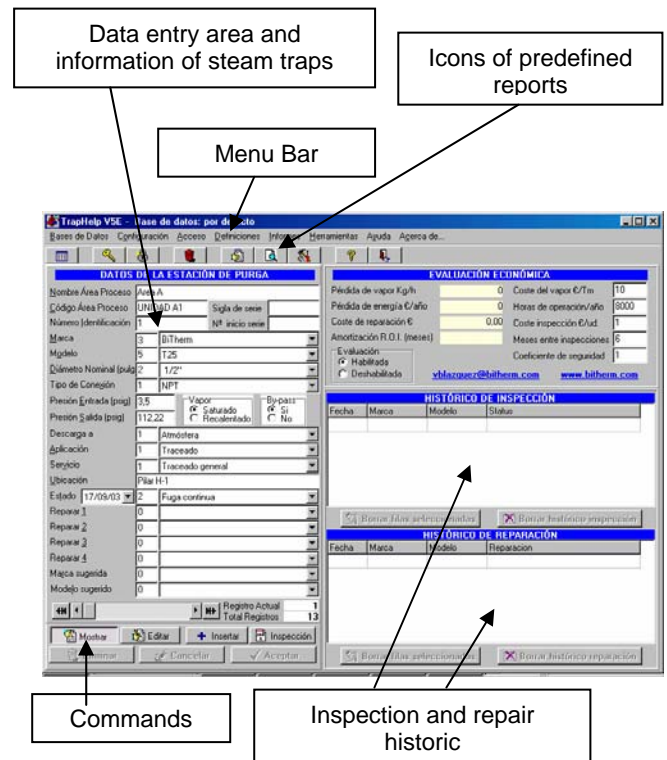

- Individual and area calculation of repair costs,
- Individual and area calculation of energy losses,
- Individual and area estimation of payback period (ROI),
- Setup options and customizable features by the user,
- Information management and filtering on screen,
- Data handling separated by process areas,
- Paradox database, compatible with other applications (Microsoft Excel, etc).

Calculation of energy losses:

Special importance has been given to the calculation of steam losses. For greater reliability, this calculation is made according to the following steam trap parameters:

- Type and model of steam trap,
- Geometry and size of the steam trap internal valve,
- Differential pressure,
- Size,
- Status,
- Discharge conditions (% flash steam in the output),
- Inspection frequency and steam cost.

Available types of report:

General Inspection Report:

Inspection data

Preconfigured reports

Fields and operators for setting reports

Economic evaluation

Inspection Charts:

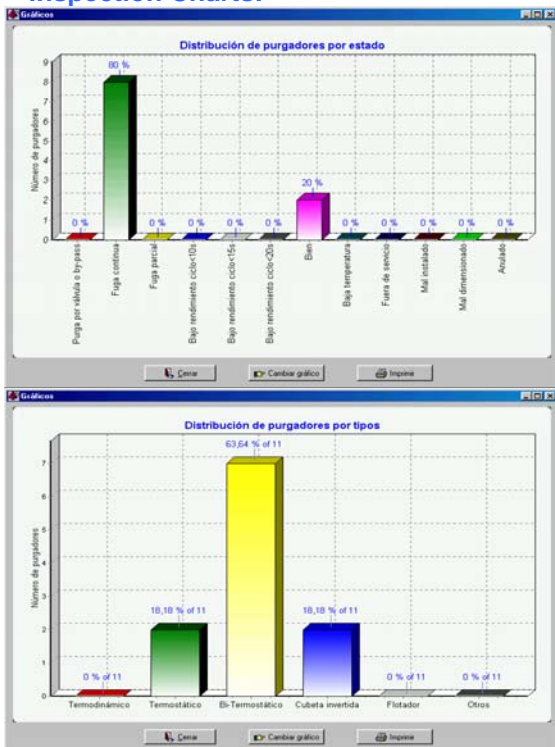

Repair Historic Report:

Definition of steam traps brands and models:

Additional information:

As can be seen, TrapHelp™ has been designed, from its origin, as a unique application focused on the analysis of steam systems and trap valve stations.

Finally, TrapHelp™ takes all advantage of a software designed and used successfully, for over 20 years, by specialists in inspection and maintenance of steam traps. This ensures reliability and high performance of TrapHelp™.

Technical modifications reserved
Copyright BiTherm 2010

STEAM TRAP T25 / G25

Description:

Bi-Thermostatic bimetallic steam trap, with corrosion resistant regulator unaffected by waterhammer and superheated steam. Balanced pressure valve. Independent seat and cone valve, and external adjustment device while running for temperature and flow discharge. Strainer type "Y".

The fact that both, cone valve and seat, be independent and located in the low flow discharge area, reduces erosion and extends the life of the trap. The condensate discharge is controlled by bimetallic thermostat, continuously adjusting to changes of condensate flow. Automatic air venting. Installation in any position. The independence of the cone valve and seat reduces dramatically the costs of its spare parts, joined to the fact that it has an external adjustment device while running, makes an extremely low maintenance cost steam trap.

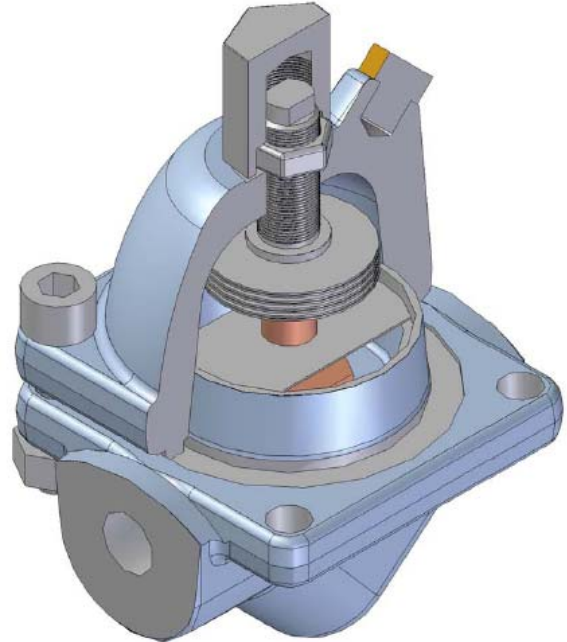
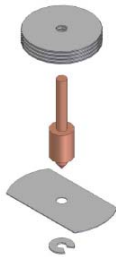

Materials:

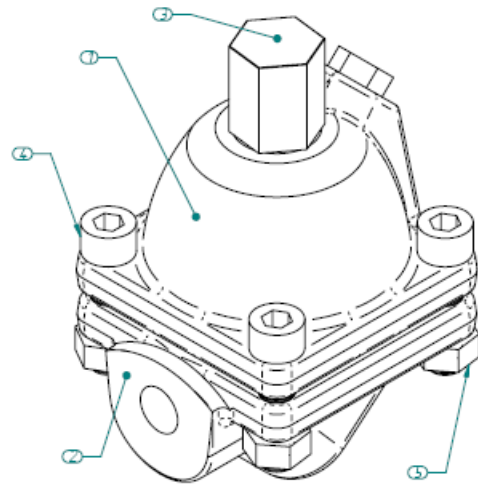

Operation:

During the start-up, the condensate is cold and the bimetals are flat. When the temperature starts to rise the bimetals will expand producing the progressive closure of the valve. In this way the steam trap is able to adjust itself to changing conditions because if the pressure rises, the higher pressure acts on the valve but at the same time the higher temperature will act on the bimetals. Its quick automatic air venting prevents air binding. The cone valve is placed on the upper stream far from the flash steam zone, this avoids erosion and waste, contributes to a long effective life and reduces maintenance costs.

Maximum operating conditions:

Maximum operating pressure: 25 bar
Maximum temperature: 400 °C
Maximum differential pressure: 25 bar

Component	Material
1 Cover	Forged steel ASTM A105
2 Body	Forged steel ASTM A105
3 Top cap	Stainless steel AISI 303
4 Screw	Forged steel ASTM A193 B16
5 Nut	Forged steel ASTM A193 B7
Seat	Stainless Steel AISI 420
Cone valve	Stainless steel X90 CrMoV18
Bimetals	Stainless steel 38/7 NiCr, 19/7 NiCr

Option Ti: Seat and cone valve coated by Titanium Nitride.

STEAM TRAP T25 / G25

Other characteristics:

This type of steam trap allows can be, continuously and remotely, monitored by SmartWatchWeb system in order to detect anomalies during operation, such as the possibility of appearance of external or internal leak, correct condensate discharge temperature in order to improve the energy efficiency of the installation, pressure and backpressure problems.

Connections:

Butt Weld: ½" y ¾"
Socket Weld: ½" y ¾"
Bridas DIN PN 10/16/25/40: DN 15,20,25
Bridas ANSI 150/300/600# RF: ½", ¾" y 1"
Specials connections on demand.

Capacity curves:

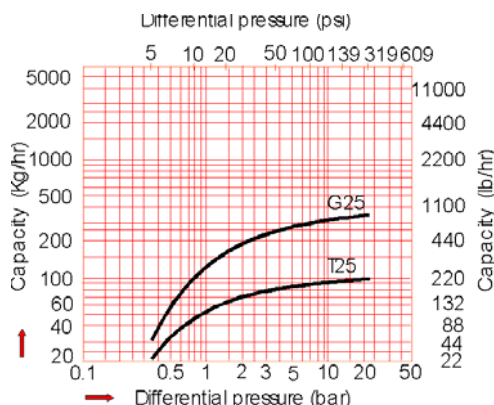

Capacities given are continuous discharge capacities of hot condensate. The cold water capacity at start-up condition will be 2.5 of the hot condensate capacity.

Dimensions:

DN (pulg)	½"	¾"	1"
H1 (mm)	89	89	89
H2 (mm)	64	64	64
L (mm)	95	95	--
B (mm) ASA150	160	158	185
B (mm) ASA300	160	185	190
B (mm) ASA600	185	185	190

Minimum disassembly distance: 60 mm.
Approximate weight (without flanges): 3,1 Kg.

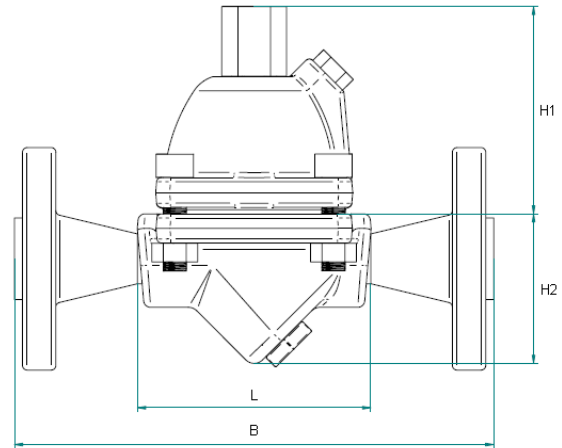

External adjustment device:

With its external adjustment device, the user can easily modify the conditions of evacuation of condensate without interrupting the pipe or trap service. To do this, simply remove the top cap (24 mm wrench), loosen the lock nut with the same wrench and turn as necessary the adjustment screw (8 mm wrench), up to get the required condensate flow or temperature (BiTherm qualified personnel adjusts every steam trap according to its operation conditions). Once adjusted, fix the safety nut with soft pressure and place back the top cap, fix tightly to achieve the total sealing. If sealing problems through the gasket are observed, replace it with an original new one.



Spare parts:

Seat.
Cone valve.

Technical modifications reserved
Copyright BiTherm 2010

STEAM TRAP P45 Ti/ G45 Ti

Description:

Bi-Thermostatic bimetallic steam trap, with corrosion resistant regulator unaffected by waterhammer and superheated steam. Balanced pressure valve. Independent seat and cone valve, and external adjustment device while running for temperature and flow discharge. Strainer type "Y".

The fact that both, cone valve and seat, be independent and located in the low flow discharge area, reduces erosion and extends the life of the trap. The condensate discharge is controlled by bimetallic thermostat, continuously adjusting to changes of condensate flow. Automatic air venting. Installation in any position. The independence of the cone valve and seat reduces dramatically the costs of its spare parts, joined to the fact that it has an external adjustment device while running, makes an extremely low maintenance cost steam trap.

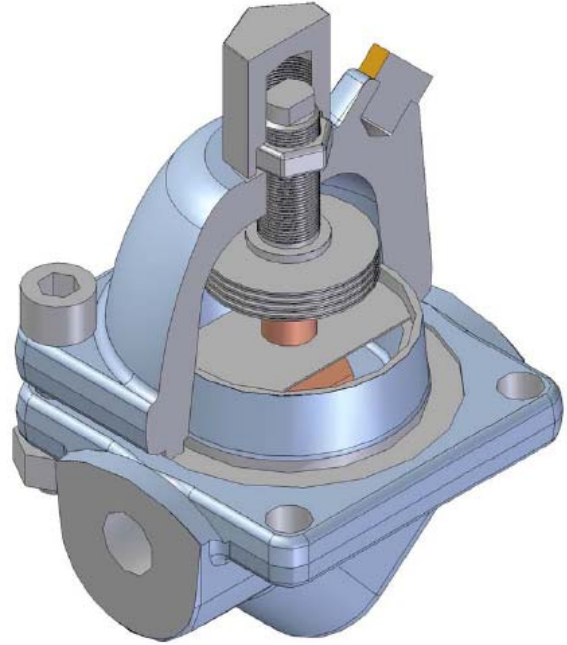
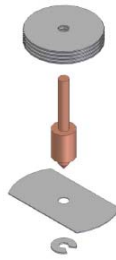

Materials:

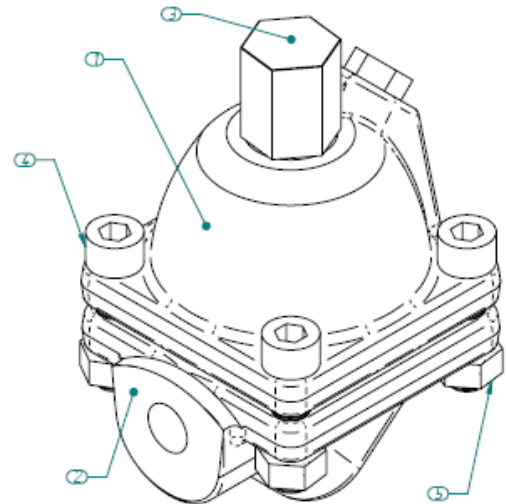

Operation:

During the start-up, the condensate is cold and the bimetals are flat. When the temperature starts to rise the bimetals will expand producing the progressive closure of the valve. In this way the steam trap is able to adjust itself to changing conditions because if the pressure rises, the higher pressure acts on the valve but at the same time the higher temperature will act on the bimetals. Its quick automatic air venting prevents air binding. The cone valve is placed on the upper stream far from the flash steam zone, this avoids erosion and waste, contributes to a long effective life and reduces maintenance costs.

Maximum operating conditions:

Maximum operating pressure: 45 bar
Maximum temperature: 400 °C
Maximum differential pressure: 45 bar

Component	Material
1 Cover	Forged steel ASTM A105
2 Body	Forged steel ASTM A105
3 Top cap	Stainless steel AISI 303
4 Screw	Forged steel ASTM A193 B16
5 Nut	Forged steel ASTM A193 B7
Seat	Stainless Steel AISI 420
Cone valve	Stainless steel X90 CrMoV18
Bimetals	Stainless steel 38/7 NiCr, 19/7 NiCr

Ti: Seat and cone valve coated by Titanium Nitride.

STEAM TRAP P45 Ti/ G45 Ti

Other characteristics:

This type of steam trap allows can be, continuously and remotely, monitored by SmartWatchWeb system in order to detect anomalies during operation, such as the possibility of appearance of external or internal leak, correct condensate discharge temperature in order to improve the energy efficiency of the installation, pressure and backpressure problems.

Connections:

Butt Weld: 1/2" y 3/4"
 Socket Weld: 1/2" y 3/4"
 Flanges DIN PN 10/16/25/40: DN 15,20,25
 Flanges ANSI 150/300/600# RF: 1/2", 3/4" y 1"
 Special connections on demand.

Capacity curves:

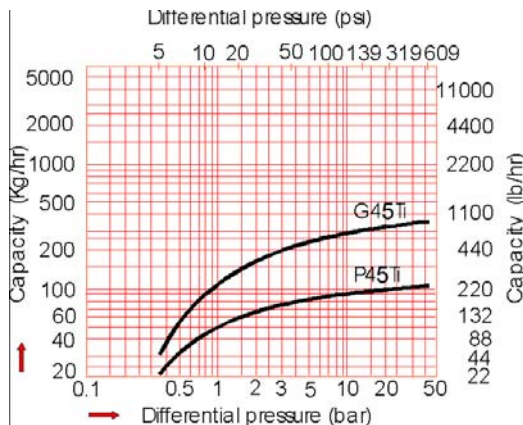

Capacities given are continuous discharge capacities of hot condensate. The cold water capacity at start-up condition will be 2.5 of the hot condensate capacity.

Dimensions:

DN (pulg)	1/2"	3/4"	1"
H1 (mm)	89	89	89
H2 (mm)	64	64	64
L (mm)	95	95	--
B (mm) ASA150	160	158	185
B (mm) ASA300	160	185	190

Minimum disassembly distance: 60 mm.
 Approximate weight (without flanges): 3,1 Kg.

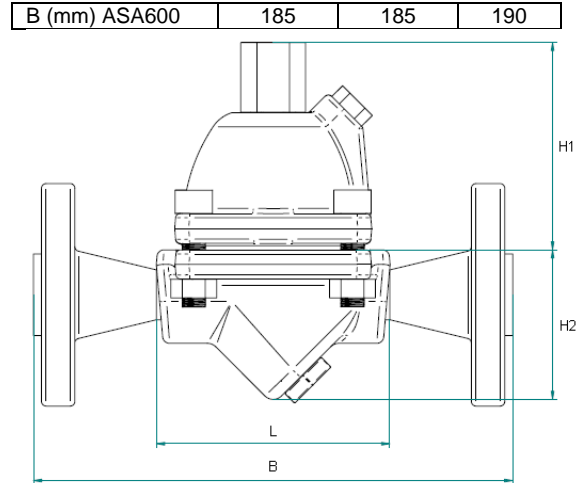

External adjustment device:

With its external adjustment device, the user can easily modify the conditions of evacuation of condensate without interrupting the pipe or trap service. To do this, simply remove the top cap (24 mm wrench), loosen the lock nut with the same wrench and turn as necessary the adjustment screw (8 mm wrench), up to get the required condensate flow or temperature (BiTherm qualified personnel adjusts every steam trap according to its operation conditions). Once adjusted, fix the safety nut with soft pressure and place back the top cap, fix tightly to achieve the total sealing. If sealing problems through the gasket are observed, replace it with an original new one.



Spare parts:

Seat.
 Cone valve.

Technical modifications reserved
 Copyright BiTherm 2010

STEAM TRAP P64 Ti/ P110 Ti

Description:

Bi-Thermostatic bimetallic steam trap, with corrosion resistant regulator unaffected by waterhammer and superheated steam. Balanced pressure valve. Independent seat and cone valve, and external adjustment device while running for temperature and flow discharge. Strainer type "Y".

The fact that both, cone valve and seat, be independent and located in the low flow discharge area, reduces erosion and extends the life of the trap. The condensate discharge is controlled by bimetallic thermostat, continuously adjusting to changes of condensate flow. Automatic air venting. Installation in any position. The independence of the cone valve and seat reduces dramatically the costs of its spare parts, joined to the fact that it has an external adjustment device while running, makes an extremely low maintenance cost steam trap.

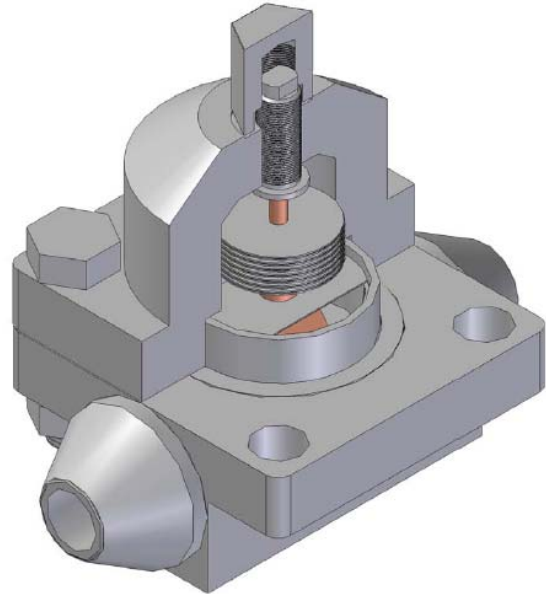
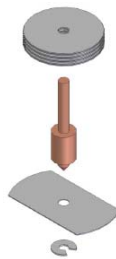

Materials:

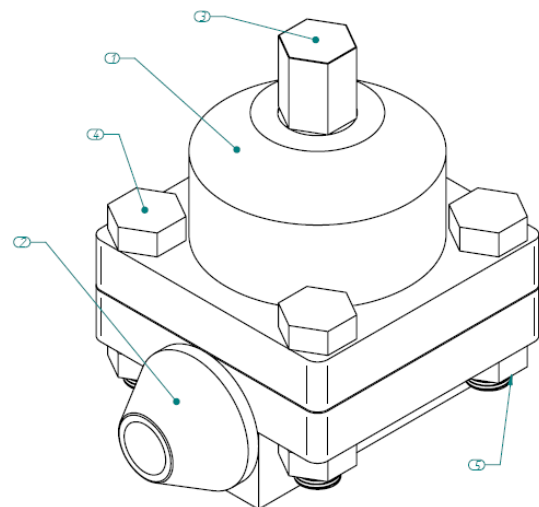

Operation:

During the start-up, the condensate is cold and the bimetals are flat. When the temperature starts to rise the bimetals will expand producing the progressive closure of the valve. In this way the steam trap is able to adjust itself to changing conditions because if the pressure rises, the higher pressure acts on the valve but at the same time the higher temperature will act on the bimetals. Its quick automatic air venting prevents air binding. The cone valve is placed on the upper stream far from the flash steam zone, this avoids erosion and waste, contributes to a long effective life and reduces maintenance costs.

Maximum operating conditions:

Maximum operating pressure: 64 / 110 bar
Maximum temperature: 525 °C
Maximum differential pressure: 64 / 110 bar

Component	Material
1 Cover	Alloy steel 13CrMo44
2 Body	Alloy steel 13CrMo44
3 Top cap	Stainless steel AISI 303
4 Screw	Forged steel ASTM A193 B16
5 Nut	Forged steel ASTM A193 B7
Seat	Stainless Steel AISI 420
Cone valve	Stainless steel X90 CrMoV18
Bimetals	Stainless steel 38/7 NiCr, 19/7 NiCr

Ti: Seat and cone valve coated by Titanium Nitride.

STEAM TRAP P64 Ti/ P110 Ti

Other characteristics:

This type of steam trap allows can be, continuously and remotely, monitored by SmartWatchWeb system in order to detect anomalies during operation, such as the possibility of appearance of external or internal leak, correct condensate discharge temperature in order to improve the energy efficiency of the installation, pressure and backpressure problems.

Connections:

Butt Weld: ½", ¾" y 1"
Socket Weld: ½", ¾" y 1"
Flanges DIN PN 160: DN 15,20,25
Flanges ANSI 600/900/1500# RF: ½", ¾" y 1"
Special connections on demand.

Capacity curves:

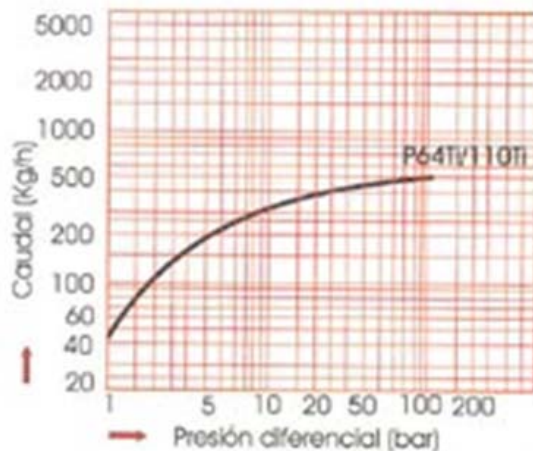

Capacities given are continuous discharge capacities of hot condensate. The cold water capacity at start-up condition will be 2.5 of the hot condensate capacity.

Dimensions:

DN (pulg)	½"	¾"	1"
H1 (mm)	122	122	122
H2 (mm)	27	27	27
L (mm)	160	160	160
B (mm)	242	262	270

Minimum disassembly distance: 80 mm.
Approximate weight (without flanges): 7 Kg.

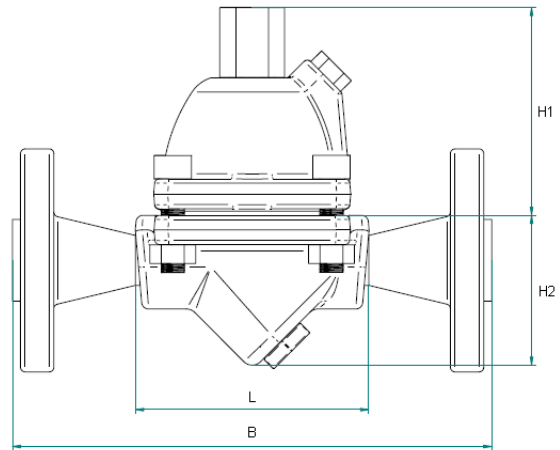

External adjustment device:

With its external adjustment device, the user can easily modify the conditions of evacuation of condensate. To do this, simply remove the top cap, loosen the lock nut and turn as necessary the adjustment screw, up to get the required condensate flow or temperature (BiTherm qualified personnel adjusts every steam trap according to its operation conditions). Once adjusted, fix the safety nut with soft pressure and place back the top cap, fix tightly to achieve the total sealing. If sealing problems through the gasket are observed, replace it with an original new one.

Spare parts:

Seat.
Cone valve.

Technical modifications reserved
Copyright BiTherm 2010

STEAM TRAP UT25 / UG25 FOR TRAP VALVE STATION

Description:

Bi-Thermostatic bimetallic steam trap, with corrosion resistant regulator unaffected by waterhammer and superheated steam. Balanced pressure valve. Independent seat and cone valve, and external adjustment device while running for temperature and flow discharge. Strainer included.

The fact that both, cone valve and seat, be independent and located in the low flow discharge area, reduces erosion and extends the life of the trap. The condensate discharge is controlled by bimetallic thermostat, continuously adjusting to changes of condensate flow. Automatic air venting. Installation in any position. The independence of the cone valve and seat reduces dramatically the costs of its spare parts, joined to the fact that it has an external adjustment device while running, makes an extremely low maintenance cost steam trap.

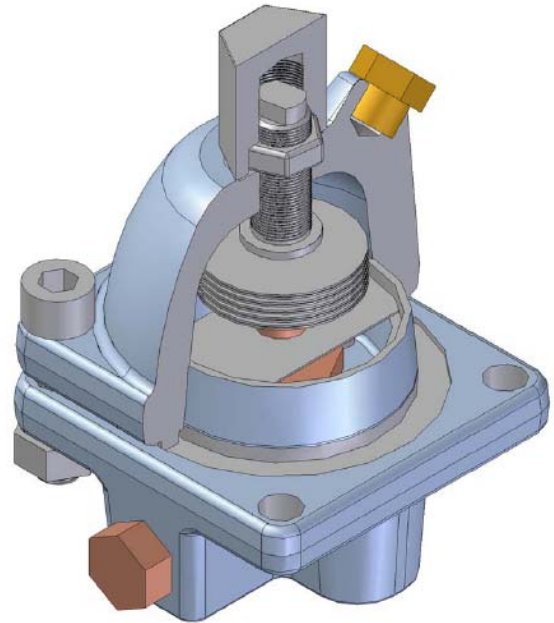
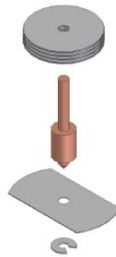

Materials:

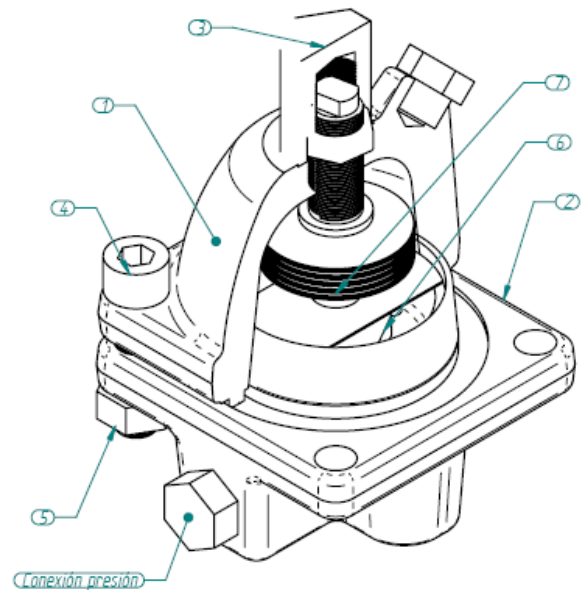

Operation:

During the start-up, the condensate is cold and the bimetals are flat. When the temperature starts to rise the bimetals will expand producing the progressive closure of the valve. In this way the steam trap is able to adjust itself to changing conditions because if the pressure rises, the higher pressure acts on the valve but at the same time the higher temperature will act on the bimetals. Its quick automatic air venting prevents air binding. The cone valve is placed on the upper stream far from the flash steam zone, this avoids erosion and waste, contributes to a long effective life and reduces maintenance costs.

Maximum operating conditions:

Maximum operating pressure: 25 bar
Maximum temperature: 400 °C
Maximum differential pressure: 25 bar

Component	Material
1 Cover	Forged steel ASTM A105
2 Body	Forged steel ASTM A105
3 Top cap	Stainless steel AISI 303
4 Screw	Forged steel ASTM A193 B16
5 Nut	Forged steel ASTM A193 B7
6 Seat	Stainless Steel AISI 420
7 Bimetals	Stainless steel 38/7 NiCr, 19/7 NiCr
Cone valve	Stainless steel X90 CrMoV18

Option Ti: Seat and cone valve coated by Titanium Nitride.

STEAM TRAP UT25 / UG25 FOR TRAP VALVE STATION

Other characteristics:

This type of steam trap allows can be, continuously and remotely, monitored by SmartWatchWeb system in order to detect anomalies during operation, such as the possibility of appearance of external or internal leak, correct condensate discharge temperature in order to improve the energy efficiency of the installation, pressure and backpressure problems.

Connections:

Universal connector to be assembled on the body of the trap valve station.

Capacity curves:

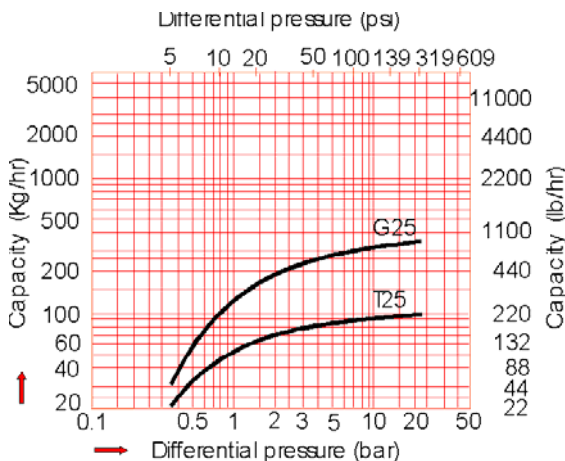

Capacities given are continuous discharge capacities of hot condensate. The cold water capacity at start-up condition will be 2.5 of the hot condensate capacity.

Dimensions:

DN (pulg)	1/2"	3/4"	1"
H1 (mm)	89	89	89
H2 (mm)	40	40	40
L (mm)	95	95	--

Minimum disassembly distance: 60 mm.

Approximate weight: 3,1 Kg.

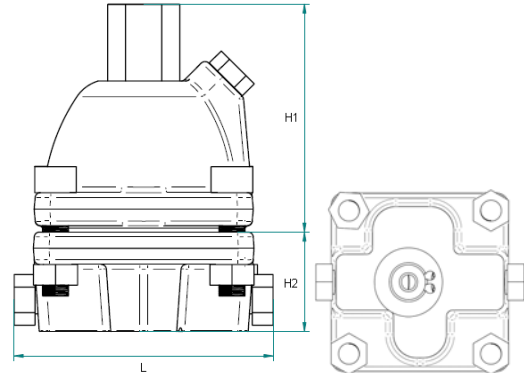

External adjustment device:

With its external adjustment device, the user can easily modify the conditions of evacuation of condensate without interrupting the pipe or trap service. To do this, simply remove the top cap (24 mm wrench), loosen the lock nut with the same wrench and turn as necessary the adjustment screw (8 mm wrench), up to get the required condensate flow or temperature (BiTherm qualified personnel adjusts every steam trap according to its operation conditions). Once adjusted, fix the safety nut with soft pressure and place back the top cap, fix tightly to achieve the total sealing. If sealing problems through the gasket are observed, replace it with an original new one.



Spare parts:

Seat.
Cone valve.

Technical modifications reserved
Copyright BiTherm 2010

PURGADORES DE CONDENSADO

www.smartwatchweb.com

Headquarter: C/ Condesa de Venadito, 16
28027 Madrid (Spain)
Tfn: 00 34 91 404 80 87

Factory: Polígono Industrial Lo Bolarín
30360 La Unión - Murcia (Spain)
Tfn: 00 34 968 54 04 45

STEAM TRAP UP45 Ti / UG45 Ti FOR TRAP VALVE STATION

Description:

Bi-Thermostatic bimetallic steam trap, with corrosion resistant regulator unaffected by waterhammer and superheated steam. Balanced pressure valve. Independent seat and cone valve, and external adjustment device while running for temperature and flow discharge. Strainer included.

The fact that both, cone valve and seat, be independent and located in the low flow discharge area, reduces erosion and extends the life of the trap. The condensate discharge is controlled by bimetallic thermostat, continuously adjusting to changes of condensate flow. Automatic air venting. Installation in any position. The independence of the cone valve and seat reduces dramatically the costs of its spare parts, joined to the fact that it has an external adjustment device while running, makes an extremely low maintenance cost steam trap.

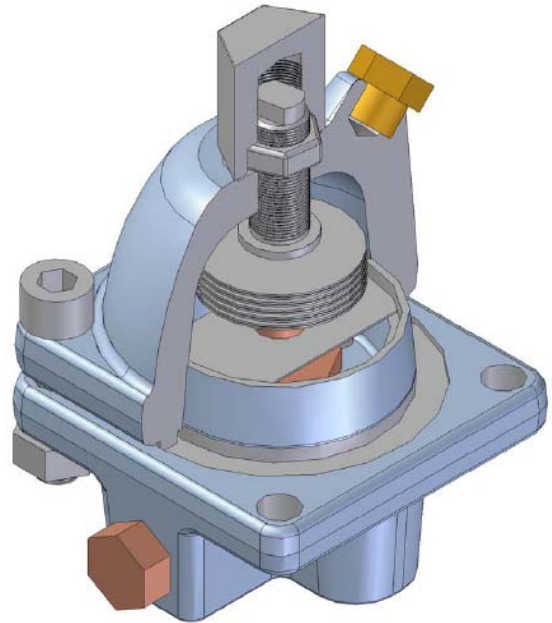
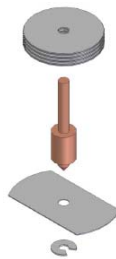

Materials:

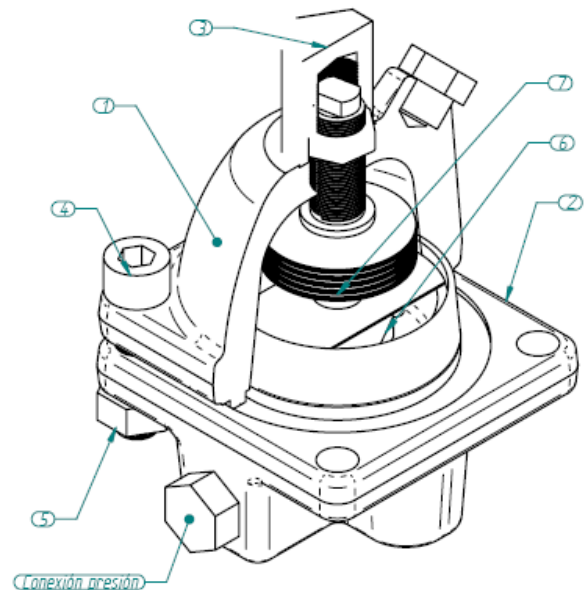

Operation:

During the start-up, the condensate is cold and the bimetals are flat. When the temperature starts to rise the bimetals will expand producing the progressive closure of the valve. In this way the steam trap is able to adjust itself to changing conditions because if the pressure rises, the higher pressure acts on the valve but at the same time the higher temperature will act on the bimetals. Its quick automatic air venting prevents air binding. The cone valve is placed on the upper stream far from the flash steam zone, this avoids erosion and waste, contributes to a long effective life and reduces maintenance costs.

Maximum operating conditions:

Maximum operating pressure: 45 bar
Maximum temperature: 400 °C
Maximum differential pressure: 45 bar

Component	Material
1 Cover	Forged steel ASTM A105
2 Body	Forged steel ASTM A105
3 Top cap	Stainless steel AISI 303
4 Screw	Forged steel ASTM A193 B16
5 Nut	Forged steel ASTM A193 B7
6 Seat	Stainless Steel AISI 420
7 Bimetals	Stainless steel 38/7 NiCr, 19/7 NiCr
Cone valve	Stainless steel X90 CrMoV18

Ti: Seat and cone valve coated by Titanium Nitride.

STEAM TRAP UP45 Ti / UG45 Ti FOR TRAP VALVE STATION

Other characteristics:

This type of steam trap allows can be, continuously and remotely, monitored by SmartWatchWeb system in order to detect anomalies during operation, such as the possibility of appearance of external or internal leak, correct condensate discharge temperature in order to improve the energy efficiency of the installation, pressure and backpressure problems.

Connections:

Universal connector to be assembled on the body of the trap valve station.

Capacity curves:

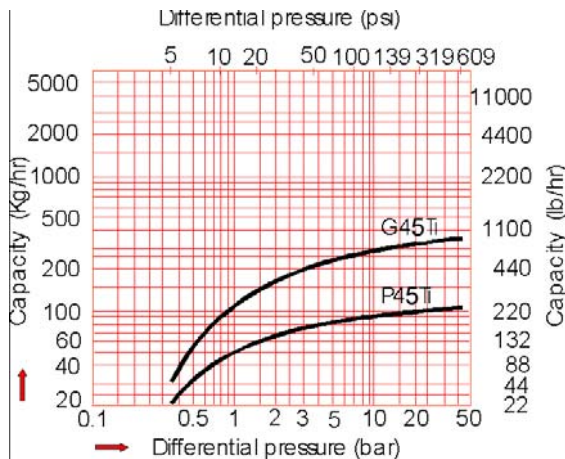

Capacities given are continuous discharge capacities of hot condensate. The cold water capacity at start-up condition will be 2.5 of the hot condensate capacity.

Dimensions:

DN (pulg)	1/2"	3/4"	1"
H1 (mm)	89	89	89
H2 (mm)	40	40	40
L (mm)	95	95	--

Minimum disassembly distance: 60 mm.
Approximate weight: 3,1 Kg.

Technical modifications reserved
Copyright BiTherm 2010

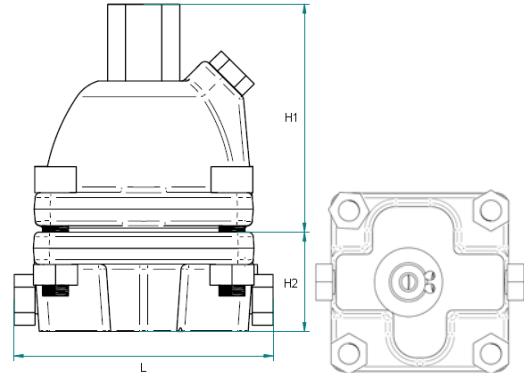

External adjustment device:

With its external adjustment device, the user can easily modify the conditions of evacuation of condensate without interrupting the pipe or trap service. To do this, simply remove the top cap (24 mm wrench), loosen the lock nut with the same wrench and turn as necessary the adjustment screw (8 mm wrench), up to get the required condensate flow or temperature (BiTherm qualified personnel adjusts every steam trap according to its operation conditions). Once adjusted, fix the safety nut with soft pressure and place back the top cap, fix tightly to achieve the total sealing. If sealing problems through the gasket are observed, replace it with an original new one.



Spare parts:

Seat.
Cone valve.

STEAM TRAP UIB 20 – UIB 40 FOR TRAP VALVE STATION

Description:

Very simple internal structure steam trap, all stainless steel, what makes it highly resistant to corrosion and water hammer. The steam trap valve controls the discontinuous condensate discharge, and also the evacuation of air and non condensable gases through the vent hole; which also is used as the control steam outlet. The UIB 20 / UIB 40 steam trap must be installed in vertical position.

This steam trap is connected to the TVS by 360° universal connector. The universal connector ensures compatibility with any other standard manufacturer.

Operation:

The steam that comes into the inverted bucket pushes it up (vertical direction) producing the close of its valve. The inverted bucket has a hole on the top that allows steam flows to the upper chamber of the trap. This steam condenses because of heat transfer to the outside, what causes the arrival of condensate to the inverted bucket, reducing its buoyancy until the bucket sinks due to weight. This cycle is repeated continuously.

It should be noted that correct operation requires the generation of an hydraulic seal in the bottom of the bucket. This is not possible with superheated steam. The discharge of this type of steam trap always happens at saturation temperature.

Maximum operating conditions:

Maximum operating pressure: 45 bar
Maximum temperature: 400 °C
Maximum differential pressure UIB 20: 14 bar
Maximum differential pressure UIB 40: 28 bar

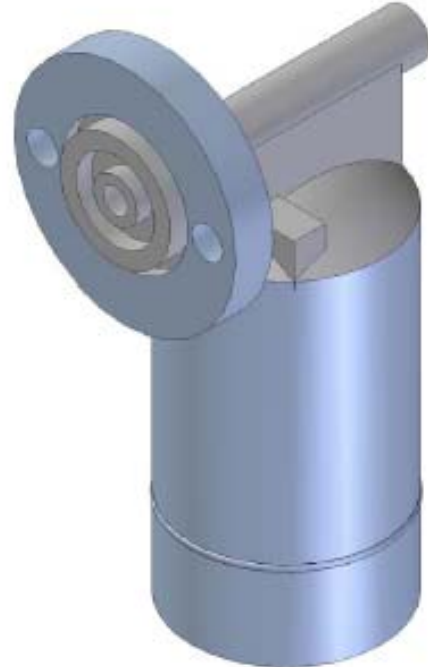

Materials:

Component	Material
Inverted Bucket	Stainless steel AISI 304
Seat	Stainless steel AISI 420
Valve	Stainless steel AISI 440B
Joints	Spiral wound
Screws	ASTM A193 B16
Nuts	ASTM A193 B7

Other characteristics:

This trap is installed on BiTherm TVS which has external mechanism to locate the continuous and remote monitoring system, SmartWatchWeb, in order to detect anomalies during operation, such as: external or internal leakage, inlet or outlet pressure problems, ...

Connections:

Universal connector to be assembled on the body of the trap valve station of any standard manufacturers, TVS.

STEAM TRAP UIB 20 – UIB 40 FOR TRAP VALVE STATION

Capacity curves:

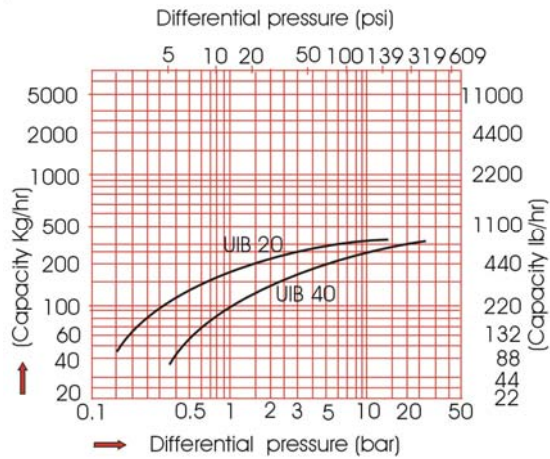

Dimensions (mm):

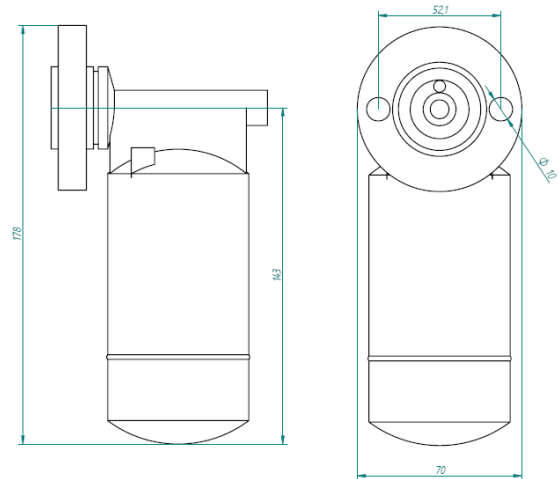

Technical modifications reserved
Copyright BiTherm 2010

PURGADORES DE CONDENSADO

www.smartwatchweb.com

Headquarter: C/ Condesa de Venadito, 16
28027 Madrid (Spain)
Tfn: 00 34 91 404 80 87

Factory: Polígono Industrial Lo Bolarín
30360 La Unión - Murcia (Spain)
Tfn: 00 34 968 54 04 45

TRAP VALVE STATION (TVS)

Elements:

The trap valve station, TVS, consists of the following:

- Body,
- Isolation piston valve (inlet),
- Isolation piston valve (outlet),
- Bypass plug,
- Trap test cum vent plug,
- Universal flange for connecting steam trap,
- SmartWatch connection.



Dimensions (mm):

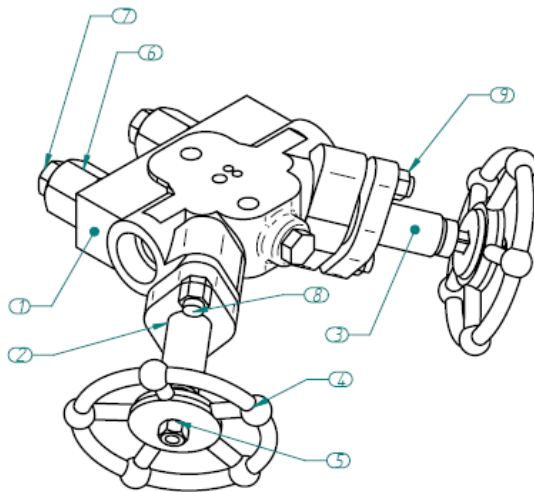
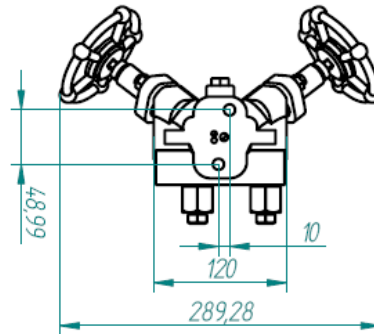
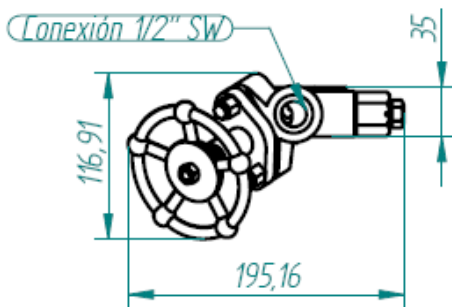

Item	Component	Material
1	Body	Forged steel ASTM A 105
2	Bonnet	Forged steel ASTM A 105
3	Spindle	Stainless steel ASTMA276 TP.410
4	Hand wheel	Cast steel ASTM A 216 Gr. WCB
5	Hand wheel nut	Stainless steel AISI 316
6	Blow down body	ASTM A 182 F316
7	Blow down screw	ASTM A 350 LF2
8	Bonnet screw	Forged steel ASTM A 193 B7
9	Bonnet nut	Steel ASTM A 194 Gr. 2H

Rings: Klinger KX-GT

Operation conditions:

Maximum operating pressure: 45 bar
Maximum temperature: 400 °C

Description:

In the operation of the TVS, piston valves have an important role. In a piston valve, the control of steam and seat leak tightness is obtained by tightness of valve sealing rings to the body and the valve piston. Flexible disc Springs automatically assure a tight seal and, so, eliminate leaks to the atmosphere or downstream pipe.

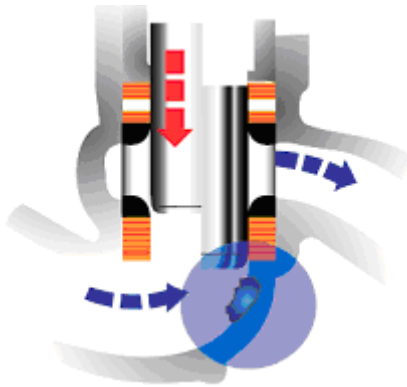
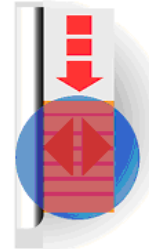

Piston valves have two clear advantages: unaffected by foreign matter in the medium and piston sliding, without turns, between the rings preventing dirt from damaging the sealing surfaces, ensuring long duration.

Trap valve station has two additional valves in the body, adjustable by wrench to ensure its operation only by qualified personnel. The purpose of these valves is to check the status of the steam trap installed on it, or serve as drainage.

Piston valve section detail:

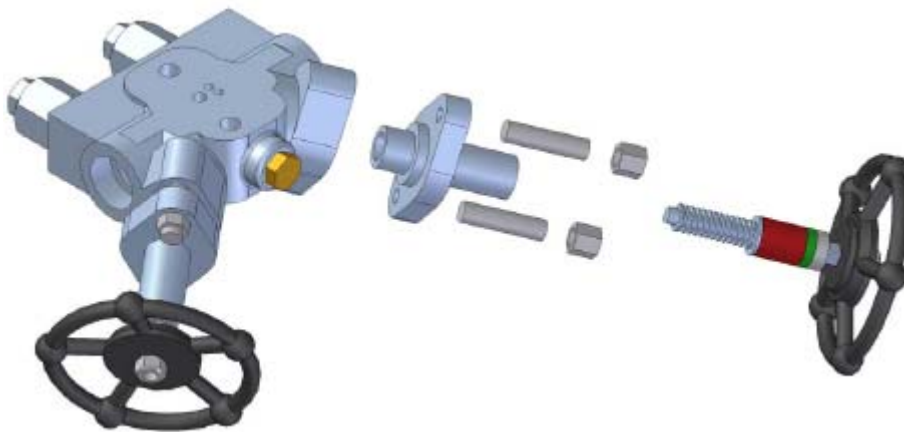

In case of spare parts replacement, only original ensure correct BiTherm TVS operation.

Technical modifications reserved

Copyright BiTherm 2010

STEAM DISTRIBUTION / CONDENSATE COLLECTION MANIFOLD CV / CC - XX

Description:

In large steam using industries, long distribution lines for steam and condensate service provide a constant source of maintenance hazards and energy wastage through numerous leakages.

BiTherm steam and condensate manifolds are designed to solve such long standing problems (vertical installation).

Fabricated headers to supply steam and collect condensate from cause a constant source of leakage. More over this also spoil the aesthetics of a well designed plant. What with continuous monetary losses due to energy wastage.

Main Features:

BiTherm steam and condensate manifolds are made from forged steel to suit various operating conditions. These are available in configurations of 4, 8 or 12 take-off points.

Integral piston valves of glandless and seatless design will ensure that leakages across seat and gland areas are eliminated totally.

Forged design minimizes the welding requirements making it much easier to operate and maintain the Readers. Standard space-saving design is for vertical installation. A simple arrangement of threaded M12 connection at the back provides a better way of attaching these manifolds to structural supports.

Available types, size and pipe connections:

Manifolds are available with 4, 8 or 12 connections. End connections flanged to ANSI class 150 or 300 or socket weld to ANSI B 16.11 Class 3000.

The steam main / condensate return connection is 40NB. The tracer line and drain connections are available as 15NB, 20 NB.

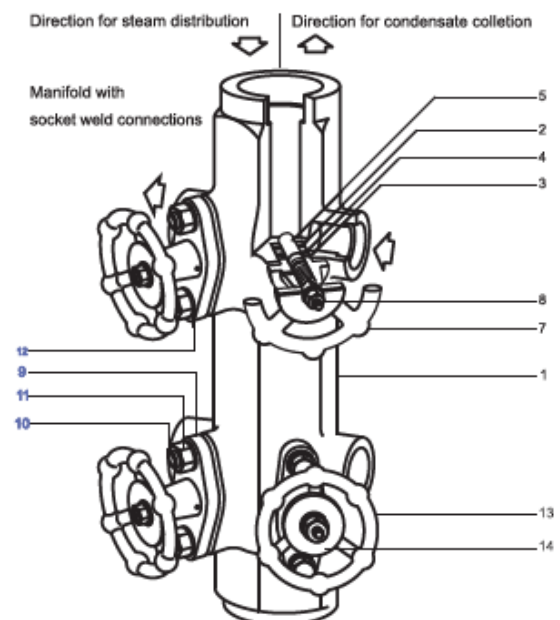

Body design conditions:

ANSI Class 300 designed for a maximum cold hydraulic test pressure of 76 bar g.

No. Part	Material	
1 Body	Carbon steel	ASTM A105N
2 Lower ring	Graphite & st. steel	KxGT
3 Upper ring	Graphite & st. steel	KxGT
4 Lantern bush	Steel	AISI 410
5 Spindle with Integral Piston	Stainless steel	AISI 410/316/ ASTMA 276 TP 410 /316
6 Handwheel	Carbon steel	ASTM 216WCB
7 Handwheel nut	Steel	AISI 316
8 Bonnet	Carbon steel	ASTM A105N
9 Studs	Alloy Steel	ASTM A193 Gr. B7
10 Nuts	Carbon Steel	ASTM A194 Gr. 2H
11 Washers	Stainless Steel	
12 Washers	Stainless Steel	

Operating range:

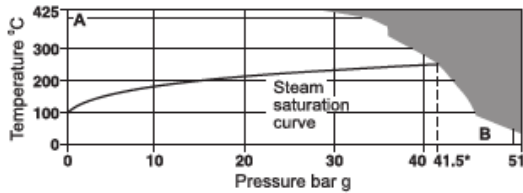

The product must not be used in this region.
 * PMO maximum operating pressure for steam service.
 For flanged connections with in the operating as per flange specs.

Note:
 The steam distribution manifolds can be made available with IBR certification.

Operation:

In operation the piston valve has should be either fully open or fully closed. It is not intended for throttling duties.

As the piston valve has such a large sealing area it is not necessary to use a valve key to ensure dead light shut-off.

Optional:

Steam distribution manifolds can be supplied with:

- Trap assembly at the bottom.
- Strainer and valve at the inlet of the manifold.

Condensate collection manifolds can be supplied with:

- Trap assembly at the bottom.
- Trap, isolation valves at individual tracing lines.
- Manifolds with take-offs in multiples of four beyond 12.

Technical modifications reserved
 Copyright BiTherm 2010

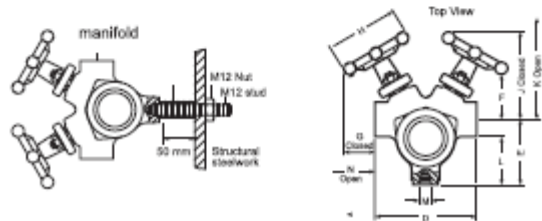
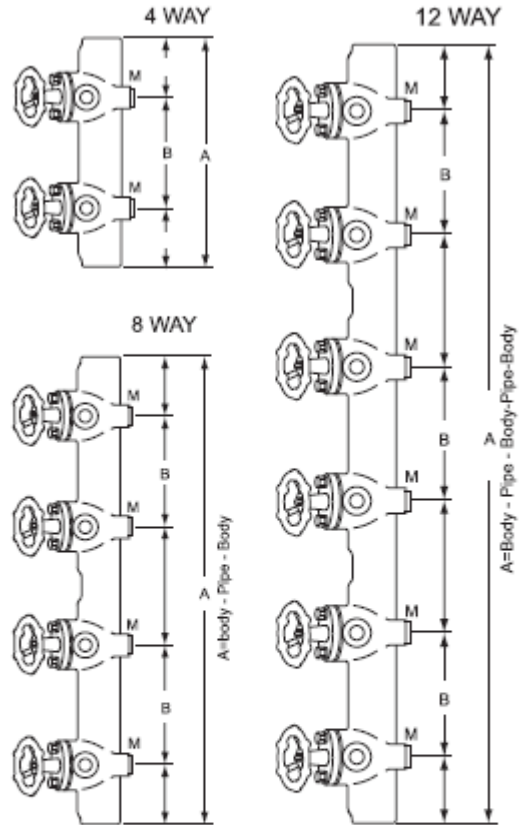

Dimensions / weights (approximate) in mm and kg

Type	A	B	C	D	E	F	G	H	J	K	L	M	N	Weight
4 WAY	275	160	57.5	110	73	80	48	86	120	135	54	M12	55	10
8 WAY	600	160	57.5	110	73	80	48	86	120	135	54	M12	55	20
12 WAY	925	160	57.5	110	73	80	48	86	120	135	54	M12	55	30

Spare parts:

- Piston valve ring sets.
- Spindle-piston assembly.
- Tool for ring extraction.

Method of ordering:

Example: 1 off BiTherm make 4 way manifold for steam distribution or condensate collection in forged carbon steel body with integral piston valves having 4 x DN20 socket weld connections to ANSI B 16. 11 Class 3000.

Description

SDG is the assembly of the steam distribution manifold for the Trap Valve Station Group (TVSG). It is composed of anchor plate, vertical stand, steam distribution manifold with insulating jacket, trap valve station at the bottom, drain valve and accessories. It is a prefabricated assembly, tested and verified functional and constructively before the supply, ready for quick installation in the field, avoiding work and assembly errors, welding, thermal insulation, paint, weld testing, hydrostatic testing and functional testing in the field. Its configuration and type of components is optional, comprising any combination of elements and test requested.

Main Features, Sizes and Connections

Their freedom of configuration provides complete flexibility to SDG specification:

- Station type: Compact / Linear.
- Dimensions: On request.
- Support profile: HEB-100 or another.
- Configuration: Linear / Sstaggered.
- Number of stations: 4, 8 or 12.
- Number of tracks without trap: On request.
- Steam trap type: Any
- Steam trap size: ½ "or ¾".
- Connections: SW, NPT or Flanged.
- Bottom drain valve: Yes
- Connection SmartWatch: Yes
- Supports for monitoring: Yes
- Range of operation: up to 45 bar.
- Materials: On request.
- Testing: On request.
- Other: On request.

This flexibility ensures compliance with all kind of requirements. Global characteristics of the SDG will correspond to those of each one of its elements, to be available on separate sheet.

Typical configurations

Pictures show typical configuration for SDG-12:

The steam distribution group SDG includes a compact trap valve station BiTherm TVS-T25 and a drain piston valve at the bottom. Its number of reserve ways must match the number of reserve ways from its corresponding trap valve station group TVSG.

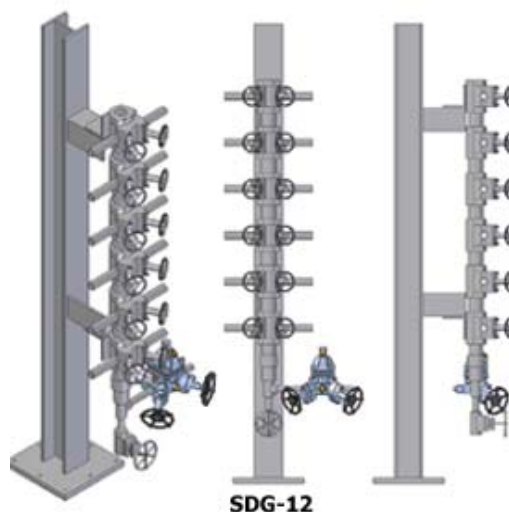

SDG-12

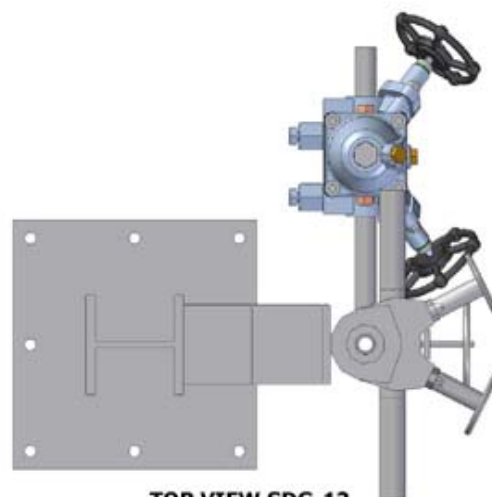

TOP VIEW SDG-12

Main advantages

Prefabrication of SDG allows all work and tests in the manufacturer's facilities obtaining the following advantages:

- Reduction of assembly work on spot (construct, assembly, weld, hidrostatic test, hardness and/or radiography test on welds, functional test, paint, thermal isolation, ...).
- Total elimination of assembly errors.
- Elimination of start-up troubles.
- Reduced cost of inspection & testing.
- Great reduction of costs and time.

Technical modifications reserved
Copyright BiTherm 2010

TRAP VALVE STATION GROUP

Description

The Trap Valve Station Group TVSG is composed of anchor plate, vertical stand, manifold with insulating jacket, trap valve stations, piston drain valve at the bottom, piping and mounting accessories. It is a prefabricated assembly, tested and verified functional and constructively before the supply, ready for quick installation in the field, avoiding work and assembly errors, welding, thermal insulation, paint, weld testing, hydrostatic testing and functional testing in the field. Its configuration and type of components is optional, comprising any combination of elements and test requested.

Main Features, Sizes and Connections

Their freedom of configuration flexibility gives the total TVSG specification:

- Station type: Compact / Linear.
- Dimensions: On request.
- Support profile: HEB-100 or another.
- Configuration: Linear / Staggered.
- Number of stations: 4, 8 or 12.
- Number of tracks without trap: On request.
- Steam trap type: Any
- Steam trap size: ½ "or ¾".
- Connections: SW, NPT or Flanged.
- Bottom drain valve: Yes
- Connection SmartWatch: Yes
- Supports for monitoring: Yes
- Range of operation: up to 45 bar.
- Materials: On request.
- Testing: On request.
- Other: On request.

This flexibility ensures compliance with all kind of requirements. Global characteristics of the TVSG will correspond to those of each one of its elements, to be available on separate sheet.

Typical configurations

Pictures show two typical configurations:

- TVSG-L12 (Linear)
- TVSG-S12 (Staggered)

Both TVSGs include 10 units of BiTherm TVS-T25 trap valve stations, 2 reserve ways without steam trap and drain piston valve at the bottom.

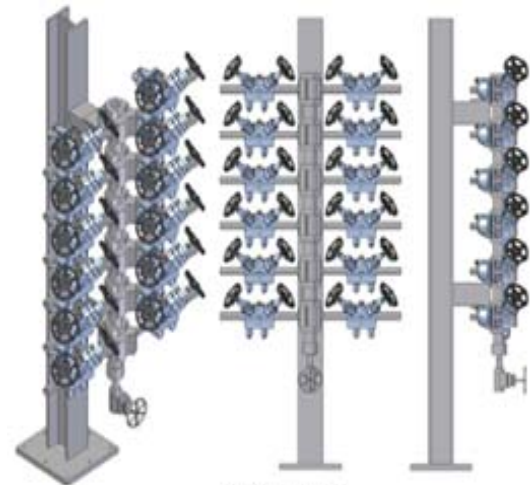

TVSG-L12

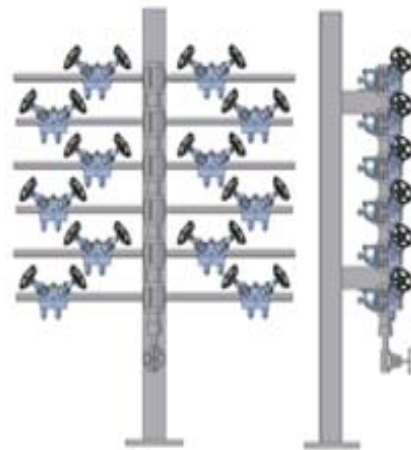

TVSG-S12

Main advantages

Prefabrication of TVSG allows all work and tests in the manufacturer's facilities obtaining the following advantages:

- Reduction of assembly work on spot (construct, assembly, weld, hidrostatic test, hardness and/or radiography test on welds, functional test, paint, thermal isolation, ...).
- Total elimination of assembly errors.
- Elimination of start-up troubles.
- Reduced cost of inspection & testing.
- Great reduction of costs and time.

Technical modifications reserved
Copyright BiTherm 2010

KIT DE ESTACIONES DE PURGA

Descripción

El kit de estaciones de purga BiTherm KEP-160 combina estaciones de purga y manifolds ofreciendo grandes beneficios. Está compuesto de los siguientes elementos: placa de anclaje, soporte vertical, manifold con chaqueta aislante removible, 4/8/12 estaciones de purga, válvula de pistón para drenaje de fondo y accesorios de tubería y ensamblaje.

Opcionalmente puede suministrarse con sifón anti-congelación, válvula superior de bloqueo, y sistema SmartWatch de monitorización (tecnología de purgadores inteligentes). Se trata de un montaje prefabricado, probado y verificado funcional y constructivamente antes del suministro, listo para su instalación rápida en campo, evitando trabajos y errores de montaje, soldadura, pintura, calorifugado, ensayos en soldaduras, pruebas hidrostáticas y/o funcionales en campo. Su configuración abarca una amplia combinación de elementos y pruebas.

Características de diseño

El kit KEP-160 flexibiliza la especificación de una amplia variedad de parámetros de diseño:

- Geometría: Lineal o al Tresbolillo
- Dimensiones: Sobre demandada
- Tipo de estación: Lineal o Compacta
- Perfil del soporte: HEB-100 u otro
- Número de estaciones de purga: 4 / 8 / 12
- Número de vías de reserva: 0 / 2
- Tipo de purgador: Cualquiera
- Tamaño de purgador: ½" o ¾"
- Conexiones: SW, NPT ó bridadas
- Válvula superior de corte: SI / NO
- Tipo de válvula superior: Globo, ...
- Válvula de drenaje: SI / NO
- Tipo de válvula de drenaje: pistón, ...
- Tamaño de válvula de drenaje: ½" o ¾"
- Chaqueta aislante removible: SI / NO
- Protección anti-congelación: SI / NO
- Conexión para SmartWatch: SI
- Soportes para monitorización: SI / NO
- Rango de operación: Hasta 45 bar
- Materiales y pruebas: Sobre demanda

Las características globales del kit KEP-160 son las de cada uno de sus elementos, que pueden consultarse en hojas técnicas separadas.

Modelos disponibles

Normalmente están disponibles dos configuraciones o geometrías típicas:

- KEP-160-L (montaje lineal)
- KEP-160-S (montaje al tresbolillo)

Cada una de ellas se suministra con 4, 8 o 12 vías.

Todos los kits KEP-160 son marcados CE según la Directiva Comunitaria PED (97/23/EC).

Las estaciones de purga TVS cumplen con el artículo 3.3 de la misma directiva.

Datos técnicos de TVS en hoja técnica separada.

Beneficios sobre métodos convencionales

Beneficios de diseño

- Prediseñado
Reduce tiempo de diseño y documentación
- Prefabricado
Calidad consistente. Garantía el funcionamiento del sistema
- Preinspeccionado:
Inspección de elementos ensamblados. Reduce tiempo de inspección

Beneficios de instalación/mantenimiento

- Reduce tiempo/coste de instalación
Menos tiempo de montaje en campo.
Evita errores de montaje.
Reduce problemas de puesta en marcha.
- Reduce tiempo de mantenimiento
Menores y más fáciles test en campo
Mayor vida útil de purgadores y válvulas
Menos pérdidas de vapor
Menores reposiciones

Beneficios de compra

- Reduce especificación y documentación
- Reduce requisición
- Reduce procedimientos de compra
- Reduce logística
- Única responsabilidad de suministro
- Reduce costes de mantenimiento y operación
- Tres años de garantía global

Derecho reservado de modificaciones técnicas
Copyright BiTherm 2010

Esquemas de montaje

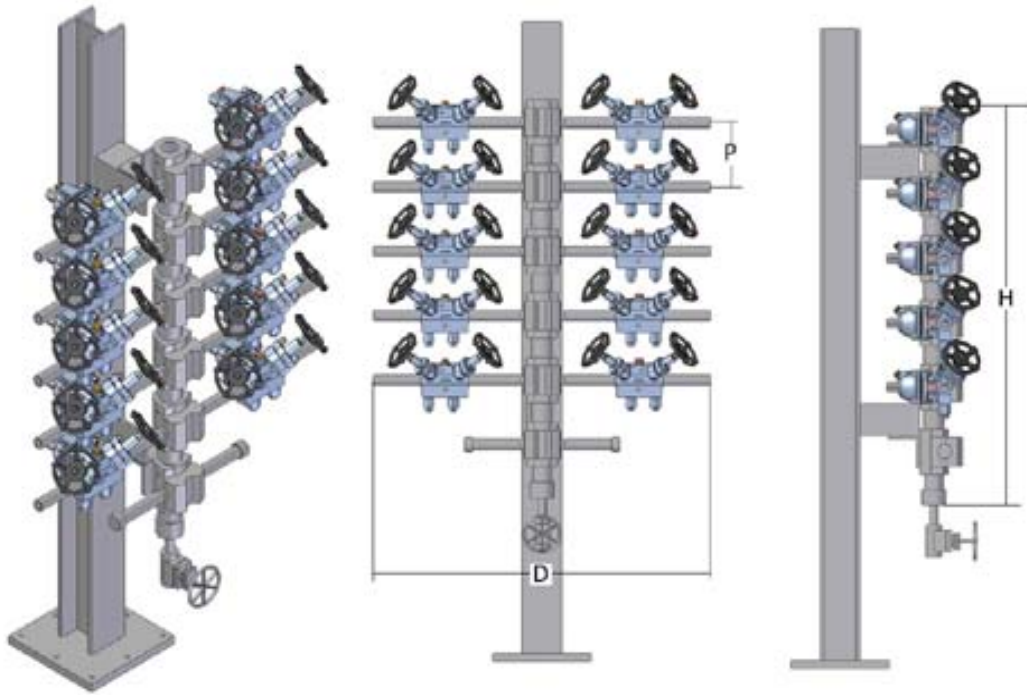

KEP-160-L12

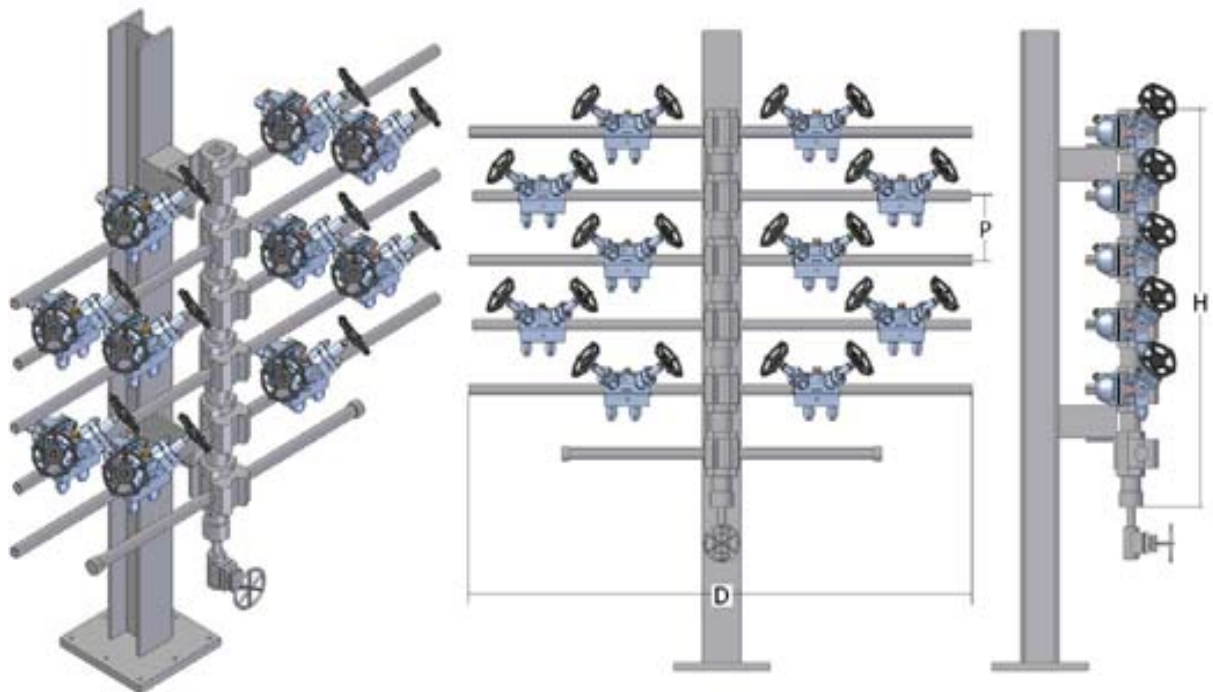

KEP-160-S12

Geometría y dimensiones

Modelo	KEP-160-L4	KEP-160-L8	KEP-160-L12	KEP-160-S4	KEP-160-S8	KEP-160-S12
Número de vías	4	8	12	4	8	12
Paso entre vías (P)	160					
Altura total (H)	324	646	989	324	646	989
Ancho total (D)	610			1050		
Diámetro salida	1.1/2"					
Diámetro drenaje	1/2" - 3/4"					
Diámetro vías	1/2" - 3/4"					
Conexión vías	SW / NPT					
Peso aprox. (Kg)	72	112	152	75	117	159
Presión max. (bar)	45 bar a 400 °C					

Todas las medidas están expresadas en mm. Otras geometrías y dimensiones sobre demanda.

Awards



Gold Medal at the International Exhibition of Inventions of Geneva (Switzerland - 2004)



Gold Medal at the International Exhibition of Inventions of Geneva (Switzerland - 2005)



Special Mention from International Jury at the International Exhibition of Inventions of Geneva (Switzerland - 2004)

Headquarters:
Madrid-Spain
www.smartwatchweb.com

Factory:
Murcia-Spain
www.smartwatchweb.com

www.smartwatchweb.com