

Instruction Manual for Compressed Air Trap

UCA

Contents.....

1. Product Overview
2. Working
3. Installation & Commissioning Instructions
4. Operations
5. Maintenance and Troubleshooting
6. Storage

UKL COMPRESSED AIR TRAP :-

UKL Compressed Air trap removes the moisture from compressed air lines, which works on the principle of Buoyancy, [densities difference of Water and Air].The rising moisture level elevates the Float and open the valve and discharges the moisture. When the level of moisture drops, the float falls down and the valve close the trap.

It is commonly used for compressed air lines and can also be used in various gases lines to drain moisture or liquid. It is a continuous discharge type trap. This trap can handle very high as well as fluctuating loads.

The moisture from compressed air lines or liquid from gas lines should be removed. UNI KLINGER provides mechanical designed Compressed Air trap which works on Buoyancy Principle and removes the moisture or liquid from gas lines. When the moisture in compressed Air lines enters the trap the increasing level of moisture elevates the Float and opens the outlet port, thus discharges the moisture, and , when the level of moisture drops, the float falls down closing the trap.



MATERIAL OF CONSTRUCTION:

CAST IRON MODEL

UCA 14 Model- IS 210 FG260

CAST CARBON STEEL MODEL

UCA 20-Model- ASTM A216 Gr. WCB

SIZES AVAILABLE:-

UCA 14 Model: 15 NB, 20 NB and 25 NB

UCA 20 Model: 15 NB, 20 NB and 25 NB

INSTALLATION :-

Horizontal/Vertical position.

END CONNECTIONS:

UCA 14 MODEL

Threaded to NPT , BSP and BSPT.

UCA 20 MODEL :-

Threaded to NPT , BSP and BSPT.

Socket Weld to ASME B 16.11

Flanged End #150/#300 (On Request)

OPERATING CONDITIONS:-

UCA 14 - CAST IRON MODEL

Max Operating Pressure :- 13.26 Kg/cm²

Max Operating Temperature :- 220 °C

UCA 20 - CAST STEEL MODEL

Max Operating Pressure :- 32 Kg/cm²

Max Operating Temperature :- 425 °C

3. Installation and Commissioning Instructions:

Your UKL make Compressed Air traps will provide you with long, trouble-free service if they are correctly installed and maintained.

A few minutes of your time spend reading these instructions now may save hours of trouble and downtime later.

- Compressed Air trap must always be installed in horizontal position, the float assembly movement must be vertical. Hence the arrow on name plate must point downwards.
- Before installing trap, the inlet piping should be carefully blown down to remove any existing pipe debris.
- A strainer must be installed on inlet line of Compressed Air Trap to ensure clean flow through trap.
- An arrow mark is punched on every trap body showing the flow direction. Install the trap by fixing the inlet & outlet ports accordingly. The traps are supplied with flow from left inlet to right outlet (L-R) or R-L. The 15/20/25 NB Float traps are supplied with vertical connections i.e. top inlet and bottom outlet.
- The connection orientation can be changed from L-R to R-L in horizontal connection on site itself by rotating cover to required direction.
- The SLR has to be opened at time of start up to avoid Air locking of the trap.
- It is advisable to install the Isolation Valves on either sides of trap to facilitate the servicing.
- It is preferable to install a 'Test Valve' at outlet & before isolation valve for testing the trap functioning.
- Testing of trap: trap can be tested either by Test Valve, pyrometer, ultrasonic stethoscope or a rod with sufficient length can be touched to the trap body & vibrations can be sensed by hands if trap is operating.

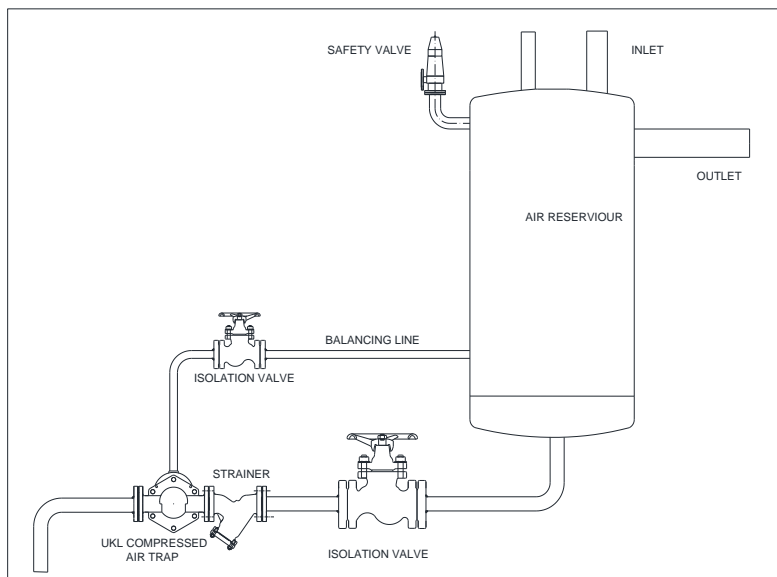

TYPICAL INSTALLATION DIAGRAM FOR COMPRESSED AIR TRAP WITH BALANCING LINE

5. Maintenance and Troubleshooting:

MAINTENANCE:

- When the Compressed Air trap will malfunction, it can be checked by observing the discharge of the trap. Compressed Air traps discharge continuously. If the trap is locked in close condition, check the maximum allowable differential pressure (stamped on the trap) is not exceeded.
- If the trap is blowing compressed Air, close the inlet valve for a few minutes, then gradually open so that the priming of the trap will take place.
- If the trap continues to blow Compressed Air, remove the trap from the line, back flush it with water, and check it again for normal operation.
- If trap do not operate normally, verify that the trap is correct for the application (capacity, differential pressure, etc.). If not correct, install a new steam trap in its place.

BILL OF MATERIAL:

UCA Size- 15 NB/20 NB/25 NB

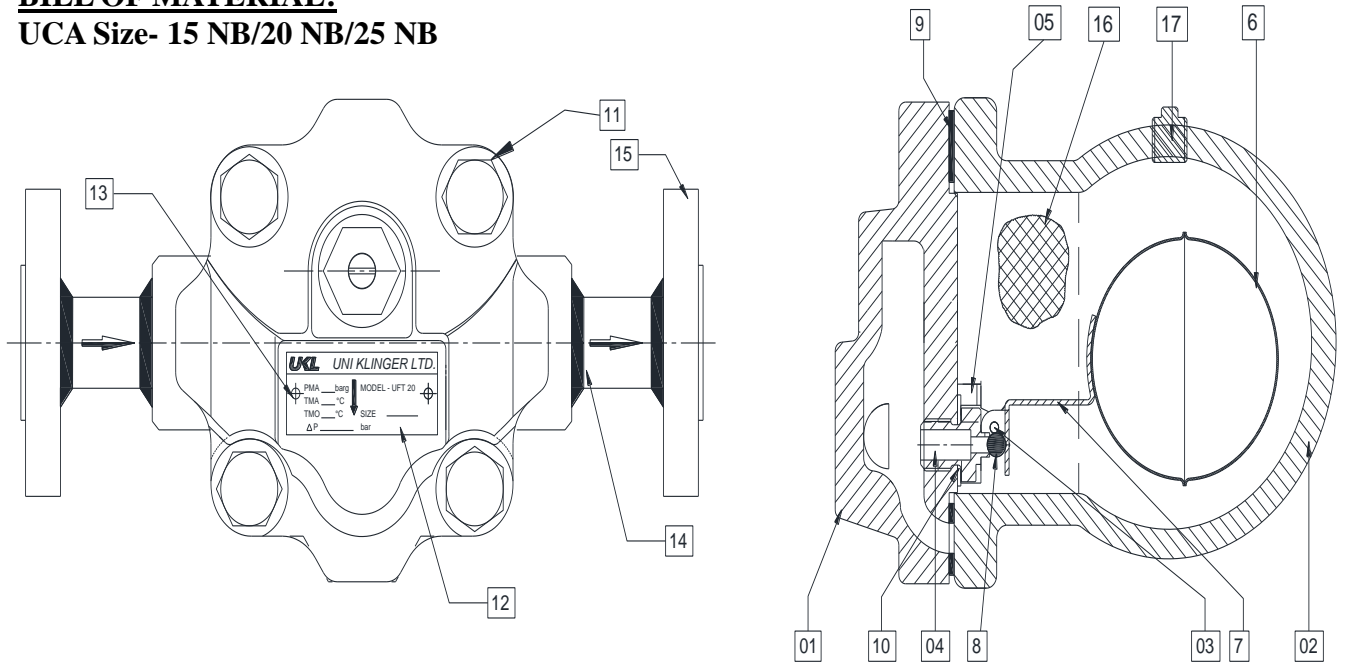

No.	PART NAME	UCA Cast Carbon Steel Model		UCA Cast Iron Model	
		MATERIAL	MATERIAL CODE	MATERIAL	MATERIAL CODE
01	Body	Cast Steel	ASTM A 216 Gr WCB	Cast Iron	IS 210 FG 260
02	Cover	Cast Steel	ASTM A 216 Gr WCB	Cast Iron	IS 210 FG 260
03	Pivot Pin	Stainless Steel	AISI 304	Stainless Steel	AISI 304
04	Valve Seat	Stainless Steel	AISI 304	Stainless Steel	AISI 304
05	Pivot Bracket	Stainless Steel	AISI 304	Stainless Steel	AISI 304
06 #	Float	Stainless Steel	AISI 304	Stainless Steel	AISI 304
07#	Lever	Stainless Steel	AISI 304	Stainless Steel	AISI 304
08#	Steel Ball	Stainless Steel	SS 440C	Stainless Steel	SS 440C
09#	Cover Gasket	CAF/ Non CAF	CAF	CAF	CAF
10#	Valve Seat Gasket	Stainless Steel	AISI 304	Stainless Steel	AISI 304
11	Cover Bolt (M10)	Carbon Steel	Gr. 8.8	Carbon Steel	Gr. 8.8
12	Name Plate	Stainless Steel	AISI 304	Stainless Steel	AISI 304
13#	Rivets	Alluminium	---	Alluminium	---
14	Pipe	Carbon Steel	ASTM A 106 Gr B	Carbon Steel	ASTM A 106 Gr B
15#	Flanges- SWRF	Carbon Steel	ASTM A 105	Carbon Steel	ASTM A 105
16	Strainer	Stainless Steel	AISI 304	Stainless steel	AISI 304
17#	End Plug	Carbon Steel	ASTM A 105	Carbon Steel	ASTM A 105

AVAILABLE AS SPARES

UKL-IM-UCA-R00-MAY 2017



PROCEDURE TO REPLACE UCA FLOAT ASSEMBLY:-

- Dismantle the body & cover by unscrewing M 10 hexagonal bolts (4 nos.)
- Dismantle the float from pivot bracket by removing pivot pin.
- Remove pivot bracket & support bracket by unscrewing M5 screws (2 nos.)
- Unscrew the valve seat.
- Replace the valve seat of appropriate differential pressure.
- Fix pivot bracket & support bracket on valve seat by screwing M 5 screws (2 nos.)
- Replace the new float assembly to pivot bracket by pivot pin (assure proper sitting of steel ball on to the valve seat orifice).
- Check for no air leakage through valve seat if air applied from outlet connection with valve in closed condition & float assembly resting on valve seat orifice by self-weight.
- If the above condition is satisfied assemble body with cover by installing the gasket provided, Assemble M10 bolts after fitting Dowell pin (Replace cover gasket & apply 30 to 35 N m . Torque)
- Hydro test the ball float trap at 1.5 times the operating pressure to ensure that there is no leakage.

TROUBLESHOOTING

- **Trap is leaking Compressed Air**
- The most likely reason for this is possible deposition of dirt on the valve seating area.
- Please ensure that the strainer screen is removed and cleaned properly. It is necessary to inspect the seat and spindle of any dirt deposition. If this is noticed, clean the surfaces and refit.
-
- **Trap is not discharging any moisture.**
- Make sure that the float has not been exposed to water hammer conditions. Float will get punctured and will soon get filled with water, loosing it's buoyancy and float does not rise on water level causing the trap to choke. Then replace the float with spare.
- Ensure that a balancing line is connected across the trap to avoid Air locking.
- These traps are most sensitive to differential pressure across the trap. If this differential pressure reduces or is nullified by high back pressure on the trap, the trap will not be able to discharge any moisture.
- Please ensure that the required differential pressure is available across the trap.
- If the problem persists, contact UKL.

6. Storage:

- UNI KLINGER UFT and the respective spares should be stored only in enclosed dry rooms in a non-aggressive atmosphere. Fully assembled Ball Float Traps must be stored as supplied by UNI KLINGER. Spare parts must be handled with care and should be stored in their original packing.
- It is recommended to take protective measures if parts are stored in dusty conditions.
- The ambient temperature in store room must be between -20 Deg. C and +50 Deg. C.
- Sudden change in temperatures must be avoided.
- Any damage due to inappropriate storage shall release UNI KLINGER of any obligations derived from warranty, guarantee, and product liability.



Cast / Forged Steel Piston Valves, Bellow seal valves, High Pressure valves (Gate/Globe) , Strainers – "Y" Type, ITVS
Steam Traps (Thermodynamic, Thermostatic, Ball Float Traps and IBT), Pressure Reducing Station, Condensate Recovery Products.
Level Gauges (Reflex, Transparent, Bicolor), Sight Glass, Hot Water Generation System, Safety and Relief Valves.
FSD Products : Compressed Asbestos / Non Asbestos Fiber Sheetting / Cut Gaskets, Spiral Wound Gaskets.

In view of technical progress design and dimensions are subjected to change without notice.

UKL® **UNI KLINGER LIMITED**
A joint venture of the Neterwala group of companies and KLINGER AG. Switzerland.

Central Sales Office & Pune Branch : SC1, 5th Fl., Kohinoor Est. Mumbai-Pune Highway, Kadaki, Pune-411 003. Tel.: +91-20-4102 3000 Fax.: (020) 4102 3001
e-mail : salesco@uniklinger.com, salespune@uniklinger.com, Website : www.uniklinger.com

Factory : C-37, M.I.D.C., Ahmednagar – 414 111, Maharashtra, Tel. : 0241 – 2777223/2777512 Fax : 0241 – 2777294, E-mail : fdworks@uniklinger.com

Branch Offices :

Baroda : 102, 1st Floor, Otel Towers-II R.C. Dutt Road, Baroda-390 005, Tel.: 91-0265-2312343/2340660, Fax.: 91-265-2341419. E-mail : salesbar@uniklinger.com
Chennai : East Coast Centre, 5th Floor, 553, Mount road, Teyanampet, Chennai - 600 018, Tel.: 91 - 44 - 24345707. Fax.: 91 - 44 - 24343960. E-mail : saleschen@uniklinger.com
Kolkata : 9, Chittrakoot, 8th Floor, 230 A, AJC Bose road, Kolkatta-700 020, Tel.: 91-33-22872510, Fax.: 91-33-22876494. E-mail : salescal@uniklinger.com
Mumbai : 22, 2nd Flr, Shreeji Arcade CHS, Almeda road, Thane-400 602, Tel.: 91-22-25421140 / 91-22-25440461, Fax.: 91-22-25440463. E-mail : salesmum@uniklinger.com
Delhi : 321, Ansal Chamber-II, 6, Bhikaji Cama Place, New Delhi-110 066, Tel.: 91-11-41658767 / 91-11-26193847, Fax.: 91-11-41658768. E-mail : salesdel@uniklinger.com