

THE PISTON VALVE principle is a KLINGER idea. One of many ideas which has achieved world-wide recognition. Continuously modified and matched to modern requirement, the piston Valve has provided itself by the millions throughout the world. Today we can say with pride that our group is worlds largest manufacturer of valves, based on this design principle. KLINGER Piston valve performance is backed by central R & D of KLINGER at Switzerland.

The shut off assembly comprises of a stainless steel piston, two resilient valve rings and a ferrous metal lantern bush. The sealing consists of the cylindrical surface of the piston and the corresponding inner surface area of the sealing rings. This provides a very large sealing compared with globe valves with conventional design- one of the reasons for the Piston valve's excellent seal.

The valve Rings are the heart of the piston valve. They are made from KXGT, a material specially developed and exclusively used for the manufacture of valve ring. KXGT consists essentially of asbestos, a high quality elastomer and graphite. KLINGER valve rings are not merely surface graphited; the graphite content extends throughout the ring. For this reason its outstanding self lubricating properties are retained throughout the rings entire service life. KLINGER valve rings are resilient, accurately dimensioned and in consequence of their good recovery characteristics have excellent form retention and long service life. KLINGER valve rings are resistant to water, steam, oils, solvents and wide range of other media. KLINGER valve rings can be used for more than 230 listed fluid media.

FEATURES:-

- Seatless and Gland less valve.
- Economic, easy to service.
- No erosion of sealing surface.
- Maintenance free.
- Compensation for thermal expansion with use of Belleville washer.
- Leak-tight across ports and to atmosphere.

END CONNECTIONS:-

Flanged #150/#300/ DIN PN40

APPLICATIONS:-

Steam, Thermic fluids, Acids, Gases, vacuum and other critical media.



MATERIAL OF CONSTRUCTION:-

- ASTM A216 Gr. WCB
- ASTM A351 Gr.CF8M (On Request)

ON REQUEST:-

- IBR/Non-IBR
- MOC : Cast Stainless / Alloy Steel
- Valve with extended spindle.
- Valve with Heating Jacket
- Pneumatic / Electrical Actuator

AVAILABLE SIZES:-

- ½", ¾", 1", 1¼", 1½" and 2"
- [1¼" available in DIN Overall length only]

INSTALLATION:-

Preferred direction is as per arrow, however this valve is a Bi Directional Valve. This valve can be installed in any position without any adverse effect on performance, seal ability or flow.

Due to soft sealing principle it is advisable to install a strainer upstream of the valve to avoid damage to the rings caused by weld slag, metal and other solid impurities.

BILL OF MATERIAL (KVN ½"-2"):-

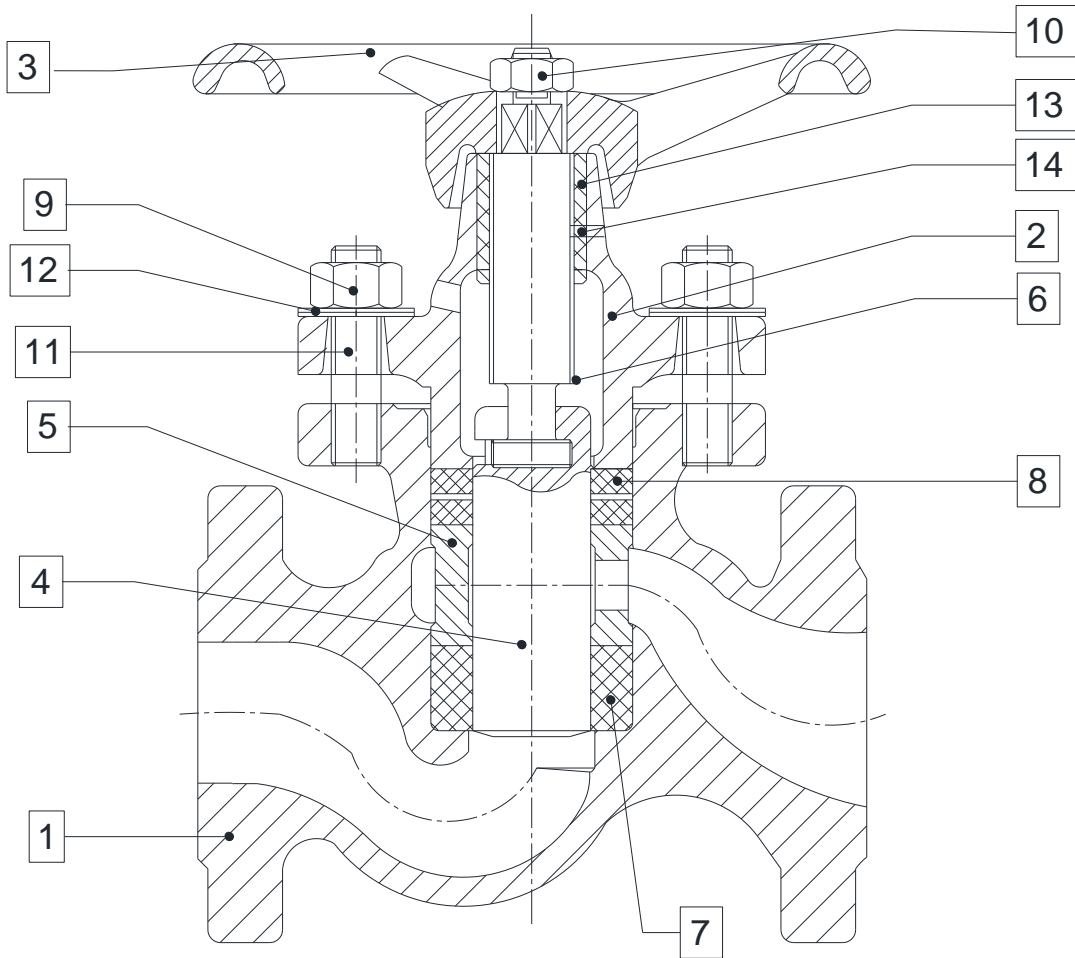

| No | PART NAME | MATERIAL | MATERIAL CODE |
|----|------------------|------------------|------------------------|
| 1 | Body | Cast Steel | ASTM A 216 Gr WCB |
| 2 | Bonnet | Cast Steel | ASTM A 216 Gr WCB |
| 3# | Hand Wheel | C.I. / M.I. | GG 20 / FG 200 / M.I. |
| 4# | Piston | Stainless Steel | Cast Equi. To AISI 430 |
| 5# | Lantern Bush | Stainless Steel | ASTM A 276 TP 410 |
| 6 | Spindle | Stainless Steel | ASTM A 276 TP 410 |
| 7# | Lower Valve Ring | Klinger Standard | KXGT |

| No | PART NAME | MATERIAL | MATERIAL CODE |
|----|-------------------|------------------|------------------|
| 8# | Upper Valve Ring | Klinger Standard | KXGT |
| 9 | Bonnet Nut | Carbon Steel | ASTM A 194 Gr 2H |
| 10 | Hand wheel Nut | Carbon Steel | ASTM A 194 Gr 2H |
| 11 | Stud Bolt | Alloy Steel | ASTM A 193 Gr B7 |
| 12 | Belleville Washer | Spring Steel | 50 Cr V4 |
| 13 | Threaded Bush | Cast Iron | GG 20 / FG 200 |
| 14 | Tension Pin | Spring Steel | 50 Cr V4 |

- Available as Spares

DIMENSIONS(inches):-(KVN ½”-2”):-

| Rating | ØD N | L | H | ØA | ØD | b | Øg | ØK | No. Of | ØI | Weight(lb) |
|--------|---------|------|-----|-----|-----|-----|-----|-----|--------|-----|------------|
| | | | | | | | | | Holes | | |
| #150 | ½” | 4.3 | 4.1 | 3.9 | 3.5 | 0.4 | 1.4 | 2.4 | 0.2 | 0.6 | 5.3 |
| | ¾” | 4.6 | 4.7 | 4.7 | 3.9 | 0.4 | 1.7 | 2.8 | 0.2 | 0.6 | 8.3 |
| | 1” | 5.0 | 5.4 | 5.5 | 4.3 | 0.5 | 2.0 | 3.1 | 0.2 | 0.6 | 12.1 |
| | 1¼” | 5.5 | 6.1 | 6.3 | 4.5 | 0.6 | 2.5 | 3.5 | 0.2 | 0.6 | 14.1 |
| | 1½” | 6.5 | 7.3 | 7.1 | 4.9 | 0.6 | 2.9 | 3.9 | 0.2 | 0.6 | 23.6 |
| | 2” | 8.0 | 8.3 | 7.1 | 5.9 | 0.7 | 3.6 | 4.8 | 0.2 | 0.8 | 30.7 |
| #300 | ½” | 6.0 | 4.1 | 3.9 | 3.7 | 0.5 | 1.4 | 2.6 | 0.2 | 0.6 | 7.6 |
| | ¾” | 7.0 | 4.7 | 4.7 | 4.5 | 0.6 | 1.7 | 3.3 | 0.2 | 0.8 | 16.7 |
| | 1” | 8.0 | 5.4 | 5.5 | 4.9 | 0.6 | 2.0 | 3.5 | 0.2 | 0.8 | 16.8 |
| | 1¼” | 8.5 | 6.1 | 6.3 | 5.3 | 0.7 | 2.5 | 3.9 | 0.2 | 0.8 | 14.6 |
| | 1½” | 9.0 | 7.3 | 7.1 | 6.1 | 0.7 | 2.9 | 4.5 | 0.2 | 0.9 | 32.5 |
| | 2” | 10.5 | 8.3 | 7.9 | 6.5 | 0.8 | 3.6 | 5.0 | 0.3 | 0.8 | 44.4 |
| PN40 | ½” | 5.1 | 4.1 | 3.9 | 3.7 | 0.6 | 1.8 | 2.6 | 0.2 | 0.6 | 7.2 |
| | ¾” | 5.9 | 4.7 | 4.7 | 4.1 | 0.7 | 2.3 | 3.0 | 0.2 | 0.6 | 15.7 |
| | 1” | 6.3 | 5.4 | 5.5 | 4.5 | 0.7 | 2.7 | 3.3 | 0.2 | 0.6 | 15.7 |
| | 1¼” | 7.1 | 6.1 | 6.3 | 5.5 | 0.7 | 3.1 | 3.9 | 0.2 | 0.7 | 14.1 |
| | 1½” | 7.9 | 7.3 | 7.1 | 5.9 | 0.7 | 3.5 | 4.3 | 0.2 | 0.7 | 31.1 |
| | 2” | 9.1 | 8.3 | 7.9 | 6.5 | 0.8 | 4.0 | 4.9 | 0.2 | 0.7 | 42.6 |

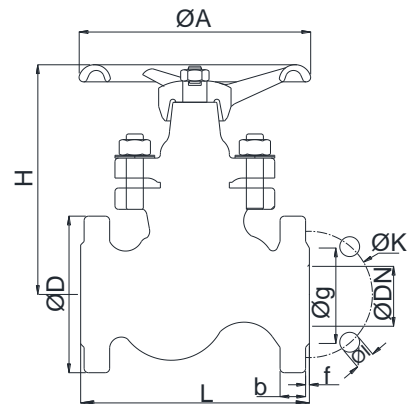

LIMITING CONDITIONS:

| Rating | Pmax (psi) | Temp°F | T max °F | Press.(psi) |
|--------|------------|--------|----------|-------------|
| #150 | 200.3 | 392 | 797 | 79.8 |
| #300 | 635.6 | 392 | 797 | 413.5 |
| PN40 | 549.9 | 392 | 797 | 325.0 |

Special Instructions:-1) Flush pipelines, 2) Open/Close the valve using hand wheel only, 3) Hot Tighen, 4) Lubricate spindle, 5) Use original Klinger rings only.

HOW TO ORDER

KLINGER PISTON VALVE KVN 1”, Steam, IBR, FLANGED TO #150

Please mention the media, its design and working pressure/Temperature

Other Products : 

Cast / Forged Steel Piston Valves, Bellow Seal Valves, High Pressure valves (Gate/Globe), Strainers – “Y” Type, Flash Vessel, Steam Traps (Thermodynamic, Thermostatic, Ball Float Traps, Inverted Bucket), Pressure Reducing Station, Condensate Recovery Products, Level Gauges (Reflex, Transparent, Bicolor), Sight Glass, Hot Water Generation System, Safety and Relief Valves.
FSD Products : Compressed Asbestos / Non Asbestos Fiber Sheeting / Cut Gaskets, Spiral Wound Gaskets.

In view of technical progress design and dimensions are subjected to change without notice.

UKL® UNI KLINGER LIMITED
 A joint venture of the Neterwala group of companies and KLINGER AG. Switzerland.

Central Sales Office & Pune Branch : SC1, 5th Fl., Kohinoor Est. Mumbai-Pune Highway, Kadaki, Pune-411 003. Tel.: +91-20-4102 3000 Fax.: (020) 4102 3001
 e-mail : salesco@uniklinger.com, salespune@uniklinger.com, Website : www.uniklinger.com

Factory : C-37, M.I.D.C., Ahmednagar – 414 111, Maharashtra, Tel. : 0241 – 2777223/2777512 Fax : 0241 – 2777294, E-mail : fdworks@uniklinger.com

Branch Offices :

Baroda : 102, 1st Floor, Otel Towers-II R.C. Dutt Road, Baroda-390 005, Tel.: 91-0265-2312343/2340660, Fax.: 91-265-2341419. E-mail : salesbar@uniklinger.com
Chennai : East Coast Centre, 5th Floor, 553, Mount road, Teyanampet, Chennai - 600 018, Tel.: 91 - 44 - 24345707. Fax.: 91 - 44 - 24343960. E-mail : saleschen@uniklinger.com
Kolkata : 9, Chittrakoot, 8th Floor, 230 A, AJC Bose road, Kolkata-700 020, Tel.: 91-33-22872510, Fax.: 91-33-22876494. E-mail : salescal@uniklinger.com
Mumbai : 22, 2nd Flr, Shreeji Arcade CHS, Almeda road, Thane-400 602, Tel.: 91-22-25421140/91-22-25440461, Fax.: 91-22-25440463. E-mail : salesmum@uniklinger.com
Delhi : 321, Ansal Chamber-II, 6, Bhikaji Cama Place, New Delhi-110 066, Tel.: 91-11-41658767/91-11-26193847, Fax.: 91-11-41658768. E-mail : salesdel@uniklinger.com